

Design for Code Acceptance

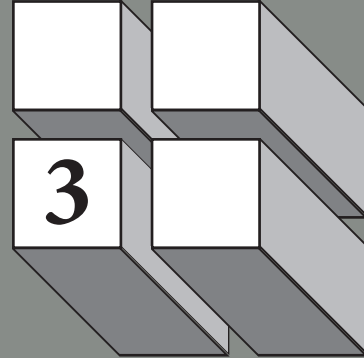

Fire-Rated Wood-Frame Wall and Floor/Ceiling Assemblies

Building Code Requirements

For occupancies such as stores, apartments, offices, and other commercial and industrial uses, building codes commonly require floor/ceiling and wall assemblies to be fire-resistance rated in accordance with standard fire tests.

Depending on the application, wall assemblies may need to be rated either from one side or both sides. For specific exterior wall applications, the model building codes allow wood-frame, wood-sided walls to be tested for exposure to fire from the inside only. Rating for both interior and exterior fire exposure is only required when the wall has a fire separation distance of less than 5 feet. Code recognition of one and two-hour wood-frame wall systems is also predicated on successful fire and hose stream testing in accordance with ASTM E119, *Standard Test Methods for Fire Tests of Building Construction Materials*.

Fire Tested Assemblies

Fire-rated wood-frame assemblies can be found in a number of sources including the *IBC*, Underwriters Laboratories (UL) *Fire Resistance Directory*, Intertek Testing Services' *Directory of Listed Products*, and the Gypsum Association's *Fire Resistance Design Manual*. The American Wood Council (AWC) and its members have tested a number of wood-frame fire-rated assemblies. Descriptions of successfully tested lumber wall assemblies are provided in [Table 1](#) for one-hour rated wall assemblies and [Table 2](#) for two-hour rated wall

assemblies. Lumber shall be identified by the grade mark of a lumber grading or inspection agency that has been approved by an accreditation body that complies with the *American Softwood Lumber Standard (PS 20)*.

Descriptions of successfully tested I-joint floor assemblies are provided in [Table 3](#) for one-hour rated floor/ceiling assemblies and [Table 4](#) for two-hour rated floor/ceiling assemblies. I-joists are required to comply with the latest version of ASTM D5055, *Standard Specification for Establishing and Monitoring Structural Capacities of Prefabricated Wood I-Joists*. Additional tests are being conducted and the Tables will be updated periodically.



Conclusions

Wood-frame assemblies are used in architectural designs because of their adaptability to style preferences, ease and economies of construction, and energy-saving performance.

2 FIRE-RATED WOOD-FRAME WALL AND FLOOR/CEILING ASSEMBLIES

Table 1 One-Hour Fire-Rated Loadbearing Wood-Frame Wall Assemblies

Assemblies Rated From Both Sides					
Studs	Insulation	Sheathing on Both Sides		Fasteners	Details
2x4 @ 16" o.c.	3½" mineral wool batts	5/8" Type X Gypsum Wallboard (H)		2¼" #6 Type S drywall screws @ 12" o.c.	WS4-1.1
2x6 @ 16" o.c.	(none)	5/8" Type X Gypsum Wallboard (H)		2¼" #6 Type S drywall screws @ 7" o.c.	WS6-1.1
2x6 @ 16" o.c.	5½" mineral wool batts	5/8" Type X Gypsum Wallboard (H)		2¼" #6 Type S drywall screws @ 12" o.c.	WS6-1.2
2x6 @ 16" o.c.	R-19 fiberglass insulation	5/8" Type X Gypsum Wallboard (V)		2¼" #6 Type S drywall screws @ 12" o.c.	WS6-1.4
Assemblies Rated From One Side (Fire on Interior Only)					
Studs	Insulation	Sheathing		Fasteners	Details
2x4 @ 16" o.c.	3½" mineral wool batts	I	5/8" Type X Gypsum Wallboard (H)	2¼" #6 Type S drywall screws @ 12" o.c.	WS4-1.2
		E	3/8" wood structural panels (V)	6d common nails @ 6" edges/12" field	
2x4 @ 16" o.c.	4 mil polyethylene 3½" mineral wool batts	I	5/8" Type X Gypsum Wallboard (V)	6d cement coated box nails @ 7" o.c.	WS4-1.3
		E	½" fiberboard (V)	1½" roofing nails @ 3" edges/6" field	
			3/8" hardboard shiplapped panel siding	8d galv. nails @ 4" edges/8" field	
2x6 @ 16" o.c.	5½" mineral wool batts	I	5/8" Type X Gypsum Wallboard (H)	2¼" #6 Type S drywall screws @ 12" o.c.	WS6-1.3
		E	7/16" wood structural panels (V)	6d common nails @ 6" edges/12" field	
2x6 @ 16" o.c.	R-19 fiberglass insulation	I	5/8" Type X Gypsum Wallboard (V)	2¼" #6 Type S drywall screws @ 12" o.c.	WS6-1.5
		E	3/8" wood structural panels (V)	6d common nails @ 6" edges/12" field	
<p style="text-align: center;">H- applied horizontally with vertical joints over studs I- Interior sheathing V- applied vertically with vertical joints over studs E- Exterior sheathing</p>					

Table 2 Two-Hour Fire-Rated Loadbearing Wood-Frame Wall Assemblies

Assemblies Rated From Both Sides					
Studs	Insulation	Sheathing on Both Sides		Fasteners	Details
2x6 @ 24" o.c.	5½" mineral wool batts	B	5/8" Type X Gypsum Wallboard (H)	2¼" #6 Type S drywall screws @ 24" o.c.	WS6-2.1
		F	5/8" Type X Gypsum Wallboard (H)	2¼" #6 Type S drywall screws @ 8" o.c.	
<p style="text-align: center;">H- applied horizontally with vertical joints over studs B- Base layer sheathing F- Face layer sheathing</p>					

Table 3 One-Hour Fire-Rated Wood Floor/Ceiling Assemblies

Wood I-Joist Assemblies						
Joists	Insulation	Furring		Ceiling Sheathing	Fasteners	Details
I-joists @ 24" o.c. Min. flange depth: 1-1/2" Min. flange area: 5.25 sq. in. Min. web thickness: 3/8" Min. I-joist depth: 9-1/4"	1-1/2" mineral wool batts (2.5 pcf-nominal) Resting on hat-shaped channels	Hat-shaped channels	F	5/8" Type C Gypsum Wallboard (GWB)	1-1/8" Type S drywall screws spaced 12" o.c. in GWB field spaced 8" o.c. at GWB end joints <i>(see fastening details)</i>	WIJ-1.1
I-joists @ 24" o.c. Min. flange depth: 1-1/2" Min. flange area: 5.25 sq. in. Min. web thickness: 7/16" Min. I-joist depth: 9-1/4"	1-1/2" mineral wool batts (2.5 pcf-nominal) Resting on resilient channels	Resilient channels	F	5/8" Type C Gypsum Wallboard (GWB)	1" Type S drywall screws spaced 12" o.c. in GWB field spaced 8" o.c. at GWB end joints <i>(see fastening details)</i>	WIJ-1.2
I-joists @ 24" o.c. Min. flange depth: 1-5/16" Min. flange area: 2.25 sq. in. Min. web thickness: 3/8" Min. I-joist depth: 9-1/4"	2" mineral wool batts (3.5 pcf-nominal) Resting on 1x4 setting strips	Resilient channels	F	5/8" Type C Gypsum Wallboard (GWB)	1-1/8" Type S drywall screws spaced 7" o.c. in GWB field spaced 7" o.c. at GWB end joints <i>(see fastening details)</i>	WIJ-1.3
I-joists @ 24" o.c. Min. flange depth: 1-1/2" Min. flange area: 3.45 sq. in. Min. web thickness: 3/8" Min. I-joist depth: 9-1/4"	1" mineral wool batts (6 pcf-nominal) Resting on hat-shaped channels under I-joist bottom flange	Hat-shaped channels supported by CSC clips	F	1/2" Type C Gypsum Wallboard (GWB)	1" Type S drywall screws spaced 12" o.c. in GWB field spaced 6" o.c. at GWB end joints <i>(see fastening details)</i>	WIJ-1.4
I-joists @ 24" o.c. Min. flange depth: 1-1/2" Min. flange area: 2.25 sq. in. Min. web thickness: 3/8" Min. I-joist depth: 9-1/4"	(none)	(none)	B	1/2" Type C Gypsum Wallboard (GWB)	1" Type S drywall screws spaced 12" o.c. in GWB field spaced 12" o.c. at GWB end joints	WIJ-1.5
			F	1/2" Type C Gypsum Wallboard (GWB)		
I-joists @ 24" o.c. Min. flange depth: 1-5/16" Min. flange area: 1.95 sq. in. Min. web thickness: 3/8" Min. I-joist depth: 9-1/2"	(none)	Resilient channels	B	1/2" Type X Gypsum Wallboard (GWB)	1-1/4" Type S drywall screws spaced 12" o.c. in GWB field spaced 12" o.c. at GWB end joints	WIJ-1.6
			F	1/2" Type X Gypsum Wallboard (GWB)		
I-joists @ 24" o.c. Min. flange depth: 1-1/2" Min. flange area: 2.25 sq. in. Min. web thickness: 3/8" Min. I-joist depth: 9-1/2"	Fiberglass batts Resting on resilient channels	Resilient channels	B	1/2" Type X Gypsum Wallboard (GWB)	1-1/4" Type S drywall screws spaced 12" o.c. in GWB field spaced 12" o.c. at GWB end joints	WIJ-1.7
			F	1/2" Type X Gypsum Wallboard (GWB)		

B- Base layer sheathing

F- Face layer sheathing

Table 4 Two-Hour Fire-Rated Wood Floor/Ceiling Assemblies

Wood I-Joist Assemblies					
Joists	Insulation	Furring	Ceiling Sheathing	Fasteners	Details
I-joists @ 24" o.c. Min. flange depth: 1-1/2" Min. flange area: 2.25 sq. in. Min. web thickness: 3/8" Min. I-joist depth: 9-1/4"	3-1/2" fiberglass insulation Supported by stay wires spaced 12" o.c.	(none)	B 5/8" Type C Gypsum Wallboard (GWB)	1-5/8" Type S drywall screws spaced 12" o.c. in GWB field spaced 12" o.c. at GWB end joints	WIJ-2.1
		Hat-shaped channels	M 5/8" Type C Gypsum Wallboard (GWB)	1" Type S drywall screws spaced 12" o.c. in GWB field spaced 12" o.c. at GWB end joints	
			F 5/8" Type C Gypsum Wallboard (GWB)	1-5/8" Type S drywall screws spaced 8" o.c. in GWB field spaced 8" o.c. at GWB end joints <i>(see fastening details)</i>	
B - Base layer sheathing (direct attached)		M - Middle layer sheathing		F - Face layer sheathing	

While every effort has been made to insure the accuracy of the information presented, the American Wood Council and its members do not assume responsibility for a particular design prepared from this publication.

For additional information or assistance contact:



American Wood Council
803 Sycolin Rd, Suite 201
Leesburg, VA 20175
<http://www.awc.org/>
202-463-2766

Copyright © 2010 American Wood Council
January 2009 & March 2010 Revisions

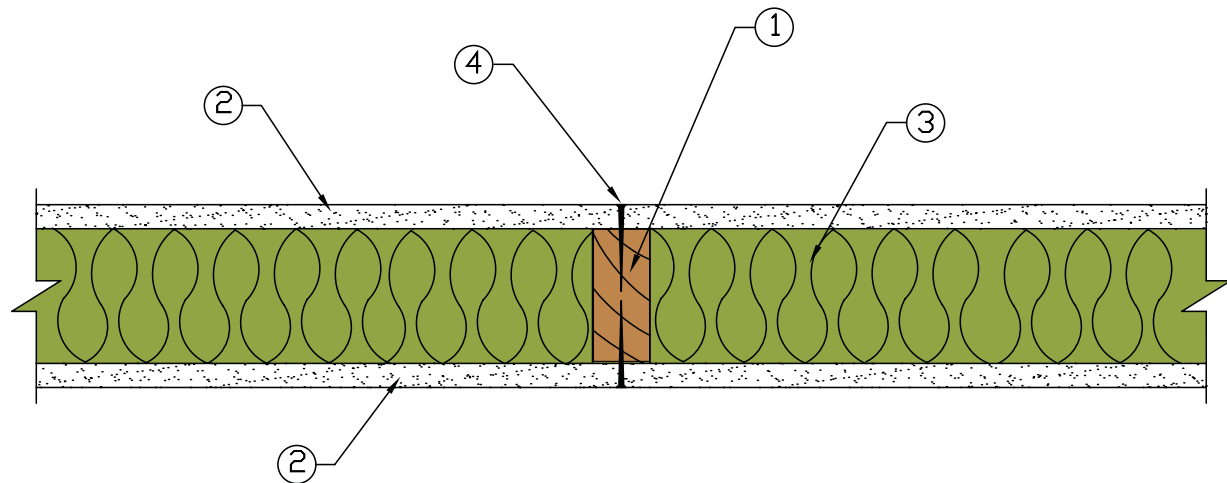
WS4-1.1 One Hour Fire-Resistive Wood-Frame Wall Assembly**2x4 Wood Stud Wall - 100% Design Load - ASTM E 119/NFPA 251**

1. Framing - Nominal 2x4 wood studs, spaced 16 in. o.c., double top plates, single bottom plate
2. Sheathing - 5/8 in. Type X gypsum wallboard, 4 ft. wide, applied horizontally. Horizontal joints are unblocked. Horizontal application of wallboard represents the direction of least fire resistance as opposed to vertical application.
3. Insulation - 3-1/2 in. thick mineral wool insulation (2.5 pcf, nominal)
4. Fasteners - 2-1/4 in. #6 Type S drywall screws, spaced 12 in. o.c.
5. Joints and Fastener Heads - Wallboard joints covered with paper tape and joint compound, fastener heads covered with joint compound

Tests conducted at the Fire Test Laboratory of National Gypsum Research Center

Test No:	WP-1248 (Fire Endurance)	March 29, 2000
	WP-1246 (Hose Stream)	March 09, 2000

Third Party Witness: Intertek Testing Services
Report J20-06170.1

This assembly was tested at 100% design load, calculated in accordance with the 2005 *National Design Specification® for Wood Construction*. The authority having jurisdiction should be consulted to assure acceptance of this report.

WS4-1.2 One-Hour Fire-Resistive Wood-Frame Wall Assembly

2x4 Wood Stud Wall - 100% Design Load - ASTM E 119/NFPA 251

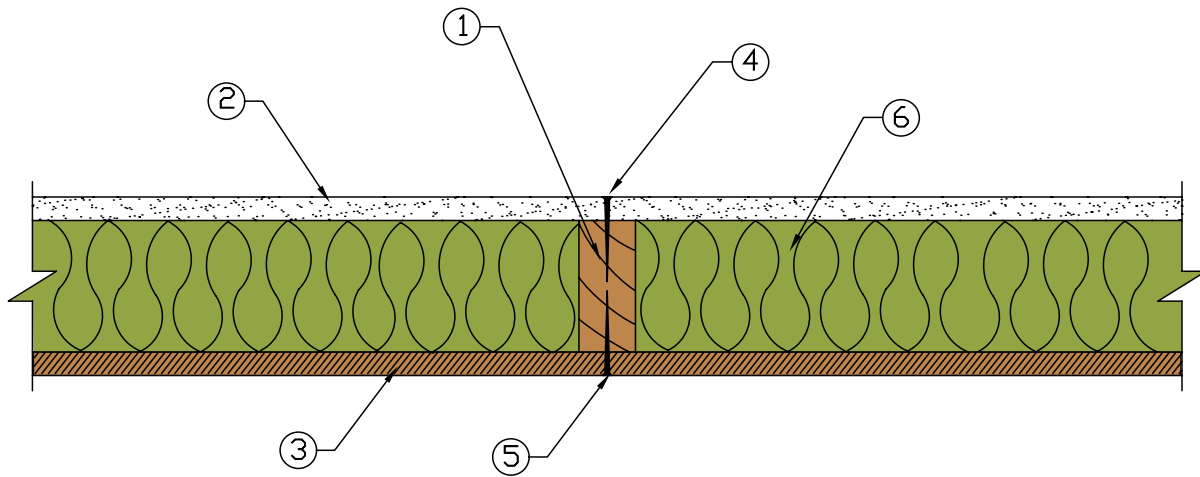

- 1 Framing - Nominal 2x4 wood studs, spaced 16 in. o.c., double top plates, single bottom plate
2. Interior Sheathing - 5/8 in. Type X gypsum wallboard, 4 ft. wide, applied horizontally. Horizontal joints are unblocked. Horizontal application of wallboard represents the direction of least fire resistance as opposed to vertical application.
3. Exterior Sheathing - 3/8 in. wood structural panels (oriented strand board), applied vertically, horizontal joints blocked
4. Gypsum Fasteners - 2-1/4 in. #6 Type S drywall screws, spaced 12 in. o.c.
5. Panel Fasteners - 6d common nails (bright) - 12 in. o.c. in the field, 6 in. o.c. panel edges
6. Insulation - 3-1/2 in. thick mineral wool insulation (2.5 pcf, nominal)
7. Joints and Fastener Heads - Wallboard joints covered with paper tape and joint compound, fastener heads covered with joint compound

Tests conducted at the Fire Test Laboratory of National Gypsum Research Center
 Test No: WP-1261 (Fire Endurance & Hose Stream) November 1, 2000

Third Party Witness: Intertek Testing Services
 Report J20-006170.2

This assembly was tested at 100% design load, calculated in accordance with the 2005 *National Design Specification® for Wood Construction*. The authority having jurisdiction should be consulted to assure acceptance of this report.

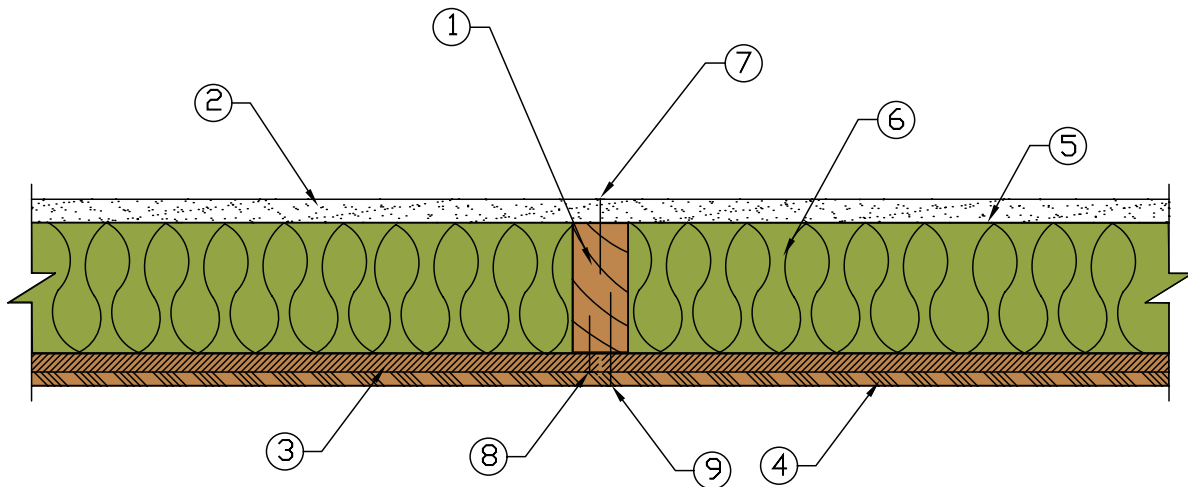
WS4-1.3 One-Hour Fire-Resistive Wood-Frame Wall Assembly**2x4 Wood Stud Wall – 78% Design Load – ASTM E 119/NFPA 251**

1. Framing - Nominal 2x4 wood studs, spaced 16 in. o.c., double top plates, single bottom plate
2. Interior Sheathing - 5/8 in. Type X gypsum wallboard, 4 ft. wide, applied vertically, unblocked
3. Exterior Sheathing - 1/2 in. fiberboard sheathing. *Alternate construction - minimum 1/2 in. lumber siding or 1/2 in. wood based sheathing.*
4. Exterior Siding - 3/8 in. hardboard shiplap edge panel siding. *Alternate construction - lumber, wood based, vinyl, or aluminum siding.*
5. Vapor Barrier - 4-mil polyethylene sheeting
6. Insulation - 3-1/2 in. thick mineral wool insulation (2.5 pcf, nominal)
7. Gypsum Fasteners - 6d cement coated box nails spaced 7 in. o.c.
8. Fiberboard Fasteners - 1-1/2 in. galvanized roofing nails - 6 in. o.c. in the field, 3 in. o.c. panel edges
9. Hardboard Fasteners - 8d galvanized nails - 8 in. o.c. in the field, 4 in. o.c. panel edges
10. Joints and Fastener Heads - Wallboard joints covered with paper tape and joint compound, fastener heads covered with joint compound

Tests conducted at the Gold Bond Building Products Fire Testing Laboratory

Test No: WP-584 (Fire Endurance & Hose Stream) March 19, 1981

Third Party Witness: Warnock Hersey International, Inc.
 Report WHI-690-003

This assembly was tested at 78% design load using an l/d of 33, calculated in accordance with the 2005 *National Design Specification® for Wood Construction*. The authority having jurisdiction should be consulted to assure acceptance of this report.

WS6-1.1 One-Hour Fire-Resistive Wood-Frame Wall Assembly

2x6 Wood Stud Wall – 100% Design Load – ASTM E 119/NFPA 251

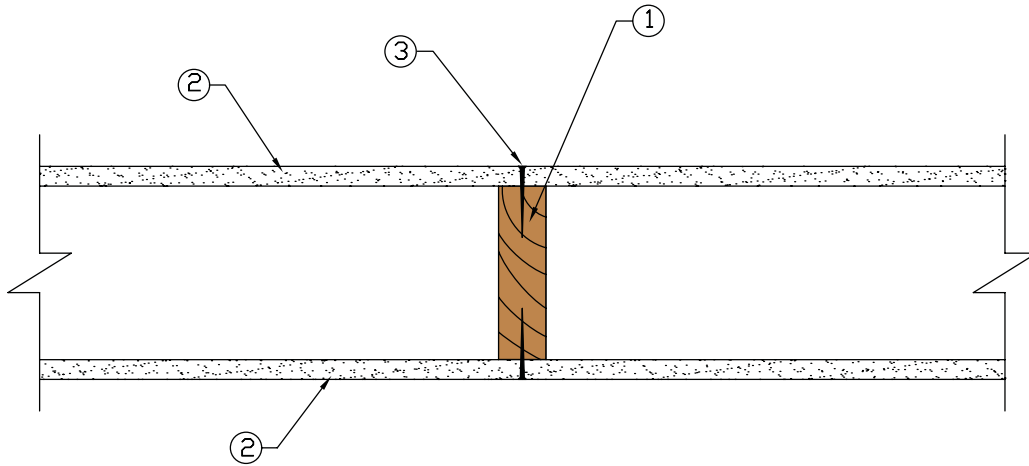

1. Framing - Nominal 2x6 wood studs, spaced 16 in. o.c., double top plates, single bottom plate
2. Sheathing - 5/8 in. Type X gypsum wallboard, 4 ft. wide, applied horizontally. Horizontal joints are unblocked. Horizontal application of wallboard represents the direction of least fire resistance as opposed to vertical application.
3. Fasteners - 2-1/4 in. #6 Type S drywall screws, spaced 7 in. o.c.
4. Joints and Fastener Heads - Wallboard joints covered with paper tape and joint compound, fastener heads covered with joint compound

Tests conducted at the Fire Test Laboratory of National Gypsum Research Center

Test No: WP-1232 (Fire Endurance)	September 16, 1999
WP-1234 (Hose Stream)	September 27, 1999

Third Party Witness: Intertek Testing Services
Report J99-22441.2

This assembly was tested at 100% design load, calculated in accordance with the 2005 *National Design Specification® for Wood Construction*. The authority having jurisdiction should be consulted to assure acceptance of this report.

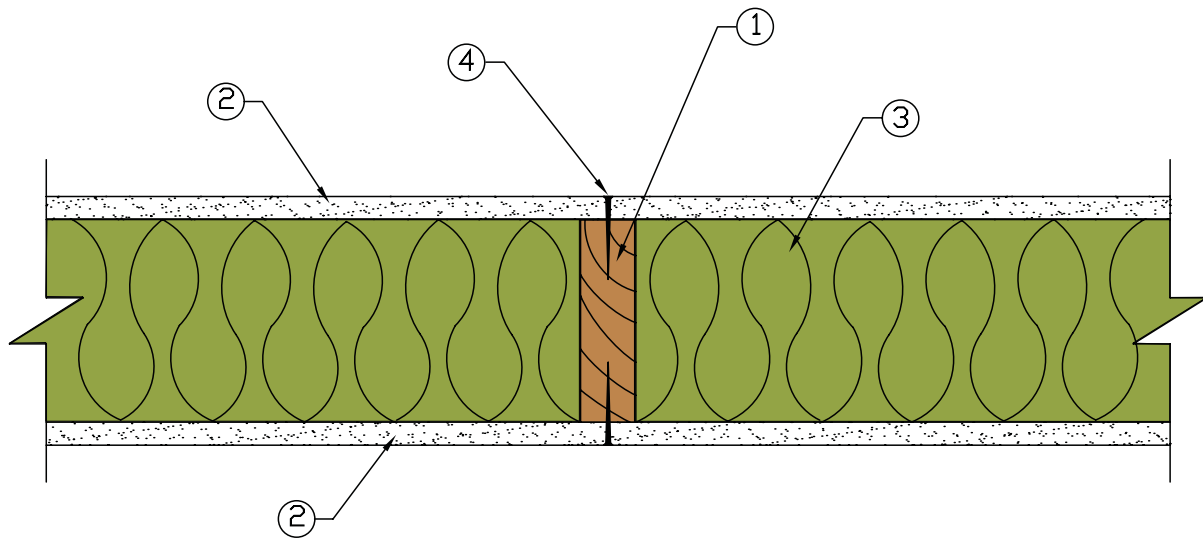
WS6-1.2 One-Hour Fire-Resistive Wood-Frame Wall Assembly**2x6 Wood Stud Wall – 100% Design Load – ASTM E 119/NFPA 251**

1. Framing - Nominal 2x6 wood studs, spaced 16 in. o.c., double top plates, single bottom plate
2. Sheathing - 5/8 in. Type X gypsum wallboard, 4 ft. wide, applied horizontally. Horizontal joints are unblocked. Horizontal application of wallboard represents the direction of least fire resistance as opposed to vertical application.
3. Insulation - 5-1/2 in. thick mineral wool insulation (2.5 pcf, nominal)
4. Fasteners - 2-1/4 in. #6 Type S drywall screws, spaced 12 in. o.c.
5. Joints and Fastener Heads - Wallboard joints covered with paper tape and joint compound, fastener heads covered with joint compound

Tests conducted at the Fire Test Laboratory of National Gypsum Research Center

Test No: WP-1231 (Fire Endurance) September 14, 1999
 WP-1230 (Hose Stream) August 30, 1999

Third Party Witness: Intertek Testing Services
 Report J99-22441.1

This assembly was tested at 100% design load, calculated in accordance with the 2005 *National Design Specification® for Wood Construction*. The authority having jurisdiction should be consulted to assure acceptance of this report.

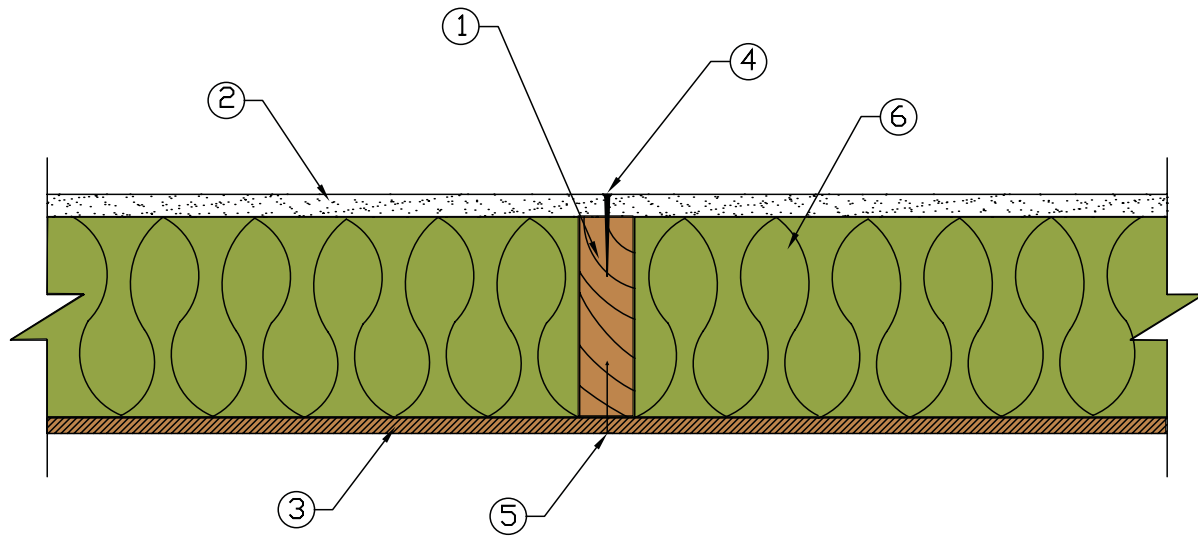
WS6-1.3 One-Hour Fire-Resistive Wood-Frame Wall Assembly**2x6 Wood Stud Wall – 100% Design Load – ASTM E 119/NFPA 251**

1. Framing - Nominal 2x6 wood studs, spaced 16 in. o.c., double top plates, single bottom plate
2. Interior Sheathing - 5/8 in. Type X gypsum wallboard, 4 ft. wide, applied horizontally. Horizontal joints are unblocked. Horizontal application of wallboard represents the direction of least fire resistance as opposed to vertical application.
3. Exterior Sheathing - 7/16 in. wood structural panels (oriented strand board), applied vertically, horizontal joints blocked
4. Gypsum Fasteners - 2-1/4 in. #6 Type S drywall screws, spaced 12 in. o.c.
5. Panel Fasteners - 6d common nails (bright) - 12 in. o.c. in the field, 6 in. o.c. panel edges
6. Insulation - 5-1/2 in. thick mineral wool insulation (2.5 pcf, nominal)
7. Joints and Fastener Heads - Wallboard joints covered with paper tape and joint compound, fastener heads covered with joint compound

Tests conducted at the Fire Test Laboratory of National Gypsum Research Center

Test No: WP-1244 (Fire Endurance & Hose Stream) February 25, 2000

Third Party Witness: Intertek Testing Services

Report J99-27259.2

This assembly was tested at 100% design load, calculated in accordance with the 2005 *National Design Specification® for Wood Construction*. The authority having jurisdiction should be consulted to assure acceptance of this report.

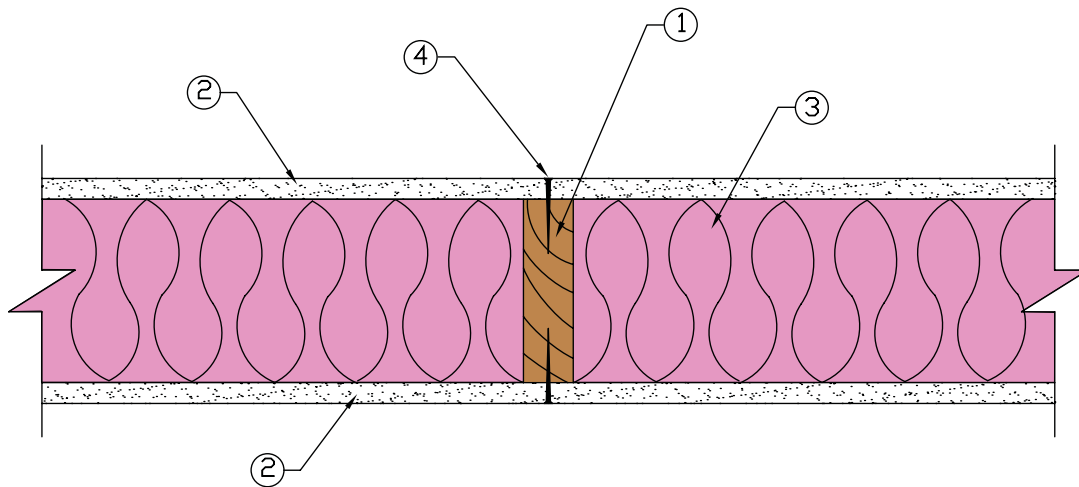
WS6-1.4 One-Hour Fire-Resistive Wood-Frame Wall Assembly**2x6 Wood Stud Wall - 100% Design Load - ASTM E 119/NFPA 251**

1. Framing - Nominal 2x6 wood studs, spaced 16 in. o.c., double top plates, single bottom plate
2. Sheathing - 5/8 in. Type X gypsum wallboard, 4 ft. wide, applied vertically. All panel edges backed by framing or blocking.
3. Insulation - R-19 fiberglass insulation
4. Fasteners - 2-1/4 in. #6 Type S drywall screws, spaced 12 in. o.c.
5. Joints and Fastener Heads - Wallboard joints covered with paper tape and joint compound, fastener heads covered with joint compound

Tests conducted at NGC Testing Services

Test No: WP-1346 (Fire Endurance) August 22, 2003
WP-1351 (Hose Stream) September 17, 2003

Third Party Witness: NGC Testing Services

This assembly was tested at 100% design load, calculated in accordance with the 2005 *National Design Specification® for Wood Construction*. The authority having jurisdiction should be consulted to assure acceptance of this report.

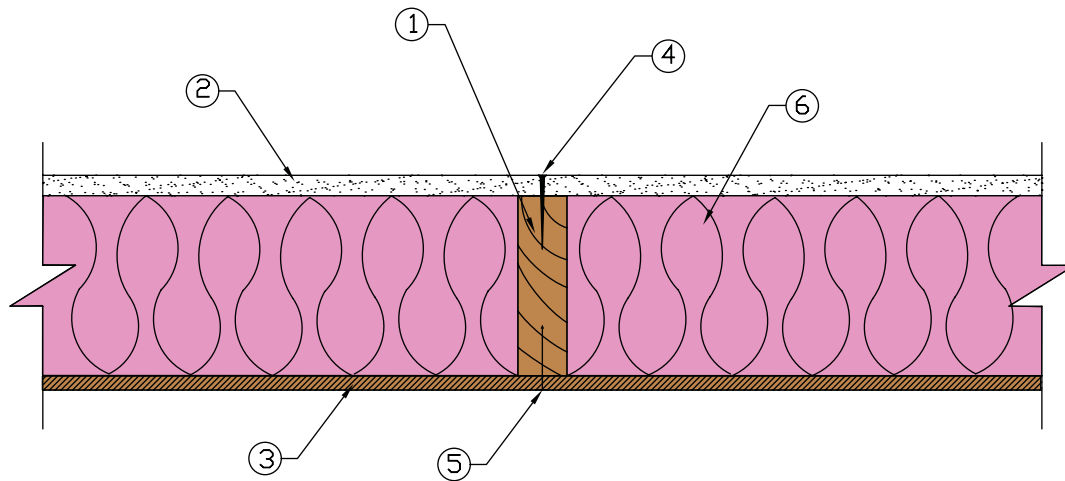
WS6-1.5 One-Hour Fire-Resistive Wood-Frame Wall Assembly**2x6 Wood Stud Wall - 100% Design Load - ASTM E 119/NFPA 251**

1. Framing - Nominal 2x6 wood studs, spaced 16 in. o.c., double top plates, single bottom plate
2. Interior Sheathing - 5/8 in. Type X gypsum wallboard, 4 ft. wide, applied vertically. All panel edges backed by framing or blocking.
3. Exterior Sheathing - 3/8 in. wood structural panels (oriented strand board), applied vertically, horizontal joints blocked
4. Gypsum Fasteners - 2-1/4 in. #6 Type S drywall screws, spaced 7 in. o.c.
5. Panel Fasteners - 6d common nails (bright) - 12 in. o.c. in the field, 6 in. o.c. panel edges
6. Insulation - R-19 fiberglass insulation
7. Joints and Fastener Heads - Wallboard joints covered with paper tape and joint compound, fastener heads covered with joint compound

Tests conducted at the NGC Testing Services

Test No: WP-1408 (Fire Endurance & Hose Stream) August 13, 2004

Third Party Witness: NGC Testing Services

This assembly was tested at 100% design load, calculated in accordance with the 2005 *National Design Specification® for Wood Construction*. The authority having jurisdiction should be consulted to assure acceptance of this report.

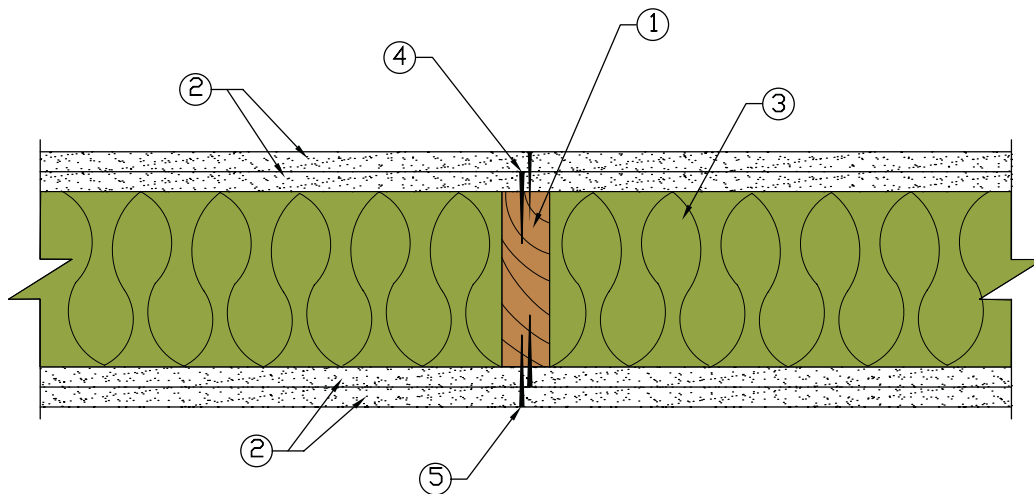
WS6-2.1 Two-Hour Fire-Resistive Wood-Frame Wall Assembly**2x6 Wood Stud Wall – 100% Design Load – ASTM E 119/NFPA 251**

1. Framing - Nominal 2x6 wood studs, spaced 24 in. o.c., double top plates, single bottom plate.
2. Sheathing:
 - Base Layer - 5/8 in. Type X gypsum wallboard, 4 ft. wide, applied horizontally, joints staggered on opposite sides of the wall.
 - Face Layer - 5/8 in. Type X gypsum wallboard, 4 ft. wide, applied horizontally, joints staggered with base layer.
 - Horizontal joints are unblocked. Horizontal application of wallboard represents the direction of least fire resistance as opposed to vertical application.
3. Insulation - 5-1/2 in. thick mineral wool insulation (2.5 pcf, nominal)
4. Gypsum Fasteners: Base Layer - 2-1/4 in. #6 Type S drywall screws, spaced 24 in. o.c.
5. Gypsum Fasteners: Face Layer - 2-1/4 in. #6 Type S drywall screws, spaced 8 in. o.c.
6. Joints and Fastener Heads - Wallboard joints covered with paper tape and joint compound, fastener heads covered with joint compound

Tests conducted at the Fire Test Laboratory of National Gypsum Research Center

Test No: WP-1262 (Fire Endurance) November 3, 2000

WP-1268 (Hose Stream) December 8, 2000

Third Party Witness: Intertek Testing Services
Report J20-006170.3

This assembly was tested at 100% design load, calculated in accordance with the 2005 *National Design Specification® for Wood Construction*. The authority having jurisdiction should be consulted to assure acceptance of this report.

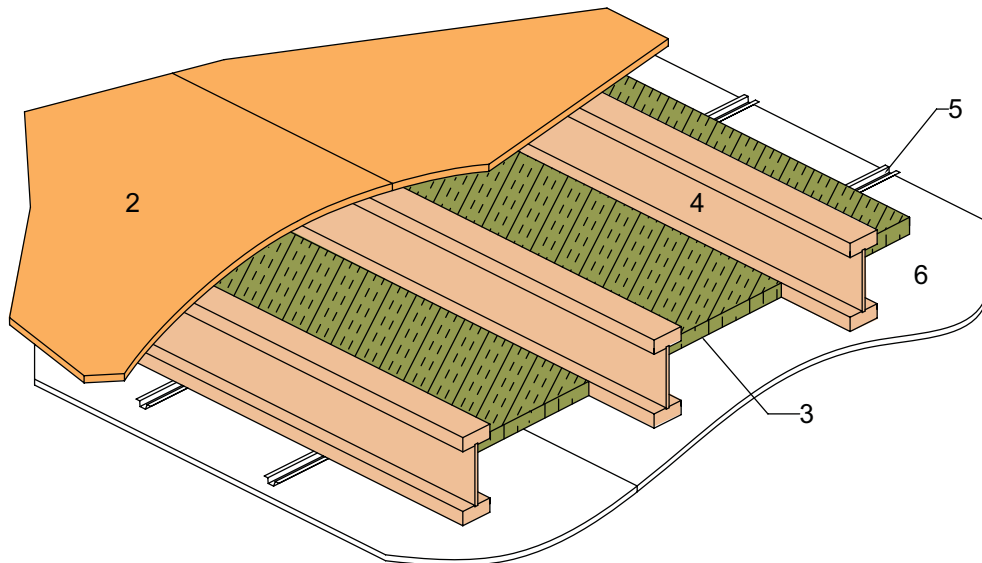
WIJ-1.1 One-Hour Fire-Resistive Ceiling AssemblyFloor^a/Ceiling - 100% Design Load - 1 Hour Rating - ASTM E 119 / NFPA 251

- 1. Floor Topping (optional, not shown):** Gypsum concrete, lightweight or normal concrete topping.
- 2. Floor Sheathing:** Minimum 23/32 inch thick tongue-and-groove wood sheathing (Exposure 1). Installed per code requirements with minimum 8d common nails and glued to joist top flanges with AFG-01 construction adhesive.
- 3. Insulation:** Minimum 1-1/2 inch thick mineral wool insulation batts – 2.5 pcf (nominal), supported by furring channels.
- 4. Structural Members:** Wood I-joists spaced a maximum of 24 inches on center.
 Minimum I-joist flange depth: 1-1/2 inches Minimum I-joist flange area: 5.25 inches²
 Minimum I-joist web thickness: 3/8 inch Minimum I-joist depth: 9-1/4 inches
 See ASTM D 5055-07 for qualification requirements.
- 5. Furring Channels:** Minimum 0.026 inch thick galvanized steel hat-shaped furring channels, attached perpendicular to I-joists using 1-5/8 inch long drywall screws. Furring channels spaced 16 inches on center and doubled at each wallboard end joint extending to the next joist.
- 6. Gypsum Wallboard:** Minimum 5/8 inch thick Type C gypsum wallboard installed with long dimension perpendicular to furring channels and fastened to each channel with minimum 1-1/8 inch long Type S drywall screws. Fasteners spaced 12 inches on center in the field of the wallboard, 8 inches on center at wallboard end joints, and 3/4 inches from panel edges and ends. End joints of wallboard staggered.
- 7. Finish System (not shown):** Face layer joints covered with tape and coated with joint compound. Screw heads covered with joint compound.

Fire Test conducted at Gold Bond Building Products Research Center
 Third Party Witness: Warnock Hersey International, Inc.

February 9, 1990
 Report No: WHI-651-0311.1

STC and IIC Sound Ratings for Listed Assembly

Without Gypsum Concrete				With Gypsum Concrete			
Cushioned Vinyl		Carpet & Pad		Cushioned Vinyl		Carpet & Pad	
STC	IIC	STC	IIC	STC	IIC	STC	IIC
-	-	-	-	-	-	49 ^b	59 ^b

^a This assembly may also be used in a fire-rated roof/ceiling application, but only when constructed exactly as described.

^b STC and IIC values estimated by David L. Adams Associates, Inc

WIJ-1.2 One-Hour Fire-Resistive Ceiling Assembly

Floor^a/Ceiling - 100% Design Load - 1 Hour Rating - ASTM E 119 / NFPA 251

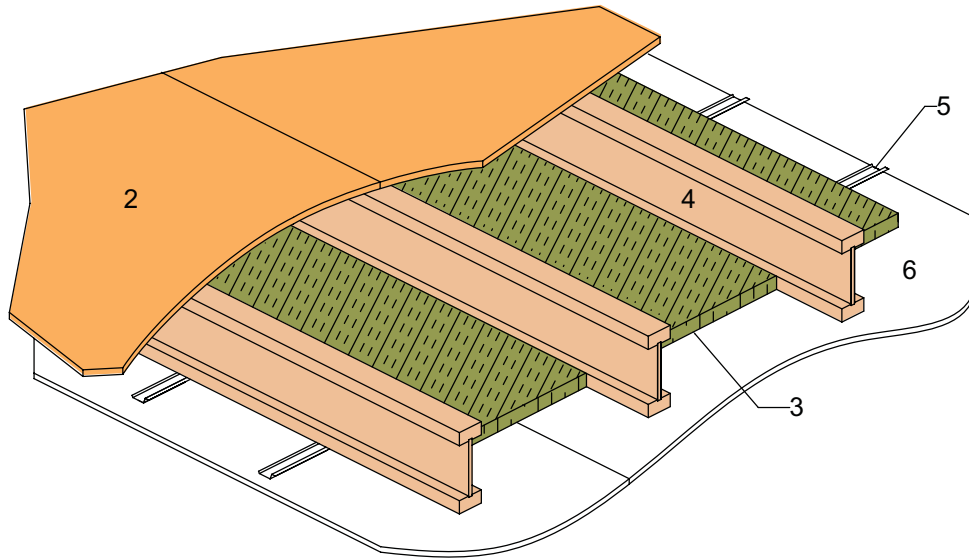

- 1. Floor Topping (optional, not shown):** Gypsum concrete, lightweight or normal concrete topping.
- 2. Floor Sheathing:** Minimum 23/32 inch thick tongue-and-groove wood sheathing (Exposure 1). Installed per code requirements with minimum 8d common nails and glued to joist top flanges with AFG-01 construction adhesive.
- 3. Insulation:** Minimum 1-1/2 inch thick mineral wool insulation batts – 2.5 pcf (nominal), supported by resilient channels.
- 4. Structural Members:** Wood I-joists spaced a maximum of 24 inches on center.
 Minimum I-joist flange depth: 1-1/2 inches Minimum I-joist flange area: 5.25 inches²
 Minimum I-joist web thickness: 7/16 inch Minimum I-joist depth: 9-1/4 inches
 See ASTM D 5055-07 for qualification requirements.
- 5. Resilient Channels:** Minimum 0.019 inch thick galvanized steel resilient channels, attached perpendicular to I-joists using 1-5/8 inch long drywall screws. Resilient channels spaced 16 inches on center and doubled at each wallboard end joint extending to the next joist.
- 6. Gypsum Wallboard:** Minimum 5/8 inch thick Type C gypsum wallboard installed with long dimension perpendicular to resilient channels and fastened to each channel with minimum 1 inch long Type S drywall screws. Fasteners spaced 12 inches on center in the field of the wallboard, 8 inches on center at wallboard end joints, and 3/4 inches from panel edges and ends. End joints of wallboard staggered.
- 7. Finish System (not shown):** Face layer joints covered with tape and coated with joint compound. Screw heads covered with joint compound.

Fire Test conducted at Gold Bond Building Products Research Center
 Third Party Witness: Warnock Hersey International, Inc.

June 19, 1984
 Report No: WHI-694-0159

STC and IIC Sound Ratings for Listed Assembly

Without Gypsum Concrete				With Gypsum Concrete			
Cushioned Vinyl		Carpet & Pad		Cushioned Vinyl		Carpet & Pad	
STC	IIC	STC	IIC	STC	IIC	STC	IIC
51 ^b	46 ^b	51 ^b	64 ^b	60 ^b	50 ^b	60 ^b	65 ^b

^a This assembly may also be used in a fire-rated roof/ceiling application, but only when constructed exactly as described.

^b STC and IIC values estimated by David L. Adams Associates, Inc

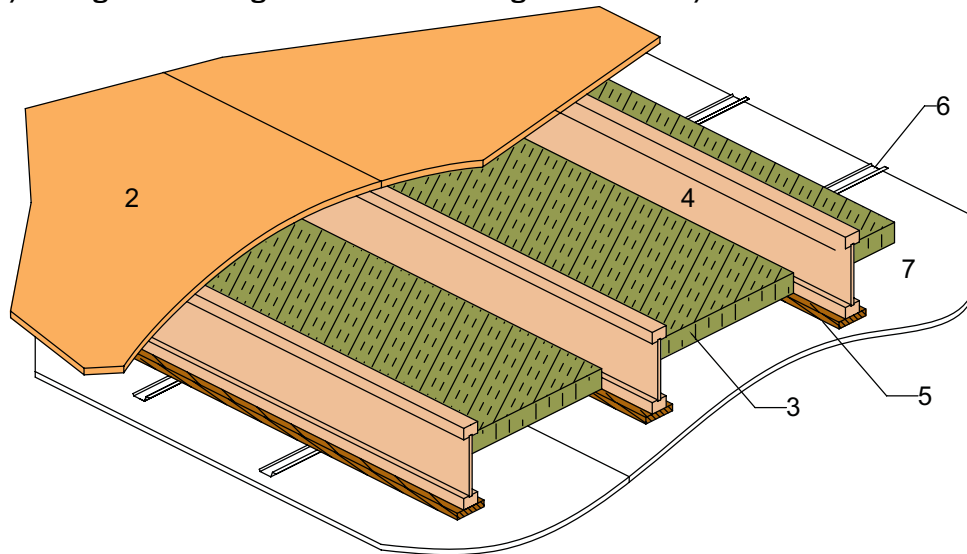
WIJ-1.3 One-Hour Fire-Resistive Ceiling AssemblyFloor^a/Ceiling - 100% Design Load - 1 Hour Rating - ASTM E 119 / NFPA 251

1. **Floor Topping (optional, not shown):** Gypsum concrete, lightweight or normal concrete topping.
2. **Floor Sheathing:** Minimum 23/32 inch thick tongue-and-groove wood sheathing (Exposure 1). Installed per code requirements.
3. **Insulation:** Minimum 2 inch thick mineral wool insulation batts – 3.5 pcf (nominal), supported by setting strip edges, friction-fitted between the sides of the I-joist flanges.
4. **Structural Members:** Wood I-joists spaced a maximum of 24 inches on center.
 Minimum I-joist flange depth: 1-5/16 inches Minimum I-joist flange area: 2.25 inches²
 Minimum I-joist web thickness: 3/8 inch Minimum I-joist depth: 9-1/4 inches
 See ASTM D 5055-07 for qualification requirements.
5. **Setting Strips:** Minimum 1x4 (nominal) wood setting strips attached with 1-1/2 inch long drywall screws at 24 inches on center along the bottom flange of I-joist creating a ledge to support insulation.
6. **Resilient Channels:** Minimum 0.019 inch thick galvanized steel resilient channels, attached perpendicular to I-joists using 1-7/8 inch long drywall screws. Resilient channels spaced 16 inches on center and doubled at each wallboard end joint extending to the next joist.
7. **Gypsum Wallboard:** Minimum 5/8 inch thick Type C gypsum wallboard installed with long dimension perpendicular to resilient channels and fastened to each channel with minimum 1-1/8 inch long Type S drywall screws. Fasteners spaced 7 inches on center and 3/4 inches from panel edges and ends. End joints of wallboard staggered.
7. **Finish System (not shown):** Face layer joints covered with tape and coated with joint compound. Screw heads covered with joint compound.

Fire Test conducted at National Gypsum Testing Services, Inc.
 Third Party Witness: Underwriter's Laboratories, Inc.

September 28, 2001
 Report No: NC3369

STC and IIC Sound Ratings for Listed Assembly

Without Gypsum Concrete				With Gypsum Concrete			
Cushioned Vinyl		Carpet & Pad		Cushioned Vinyl		Carpet & Pad	
STC	IIC	STC	IIC	STC	IIC	STC	IIC
51 ^b	46 ^b	52	66	60 ^b	48 ^b	60 ^b	60 ^b

^a This assembly may also be used in a fire-rated roof/ceiling application, but only when constructed exactly as described.

^b STC and IIC values estimated by David L. Adams Associates, In

WIJ-1.4 One-Hour Fire-Resistive Ceiling Assembly

Floor^a/Ceiling - 100% Design Load - 1 Hour Rating - ASTM E 119 / NFPA 251

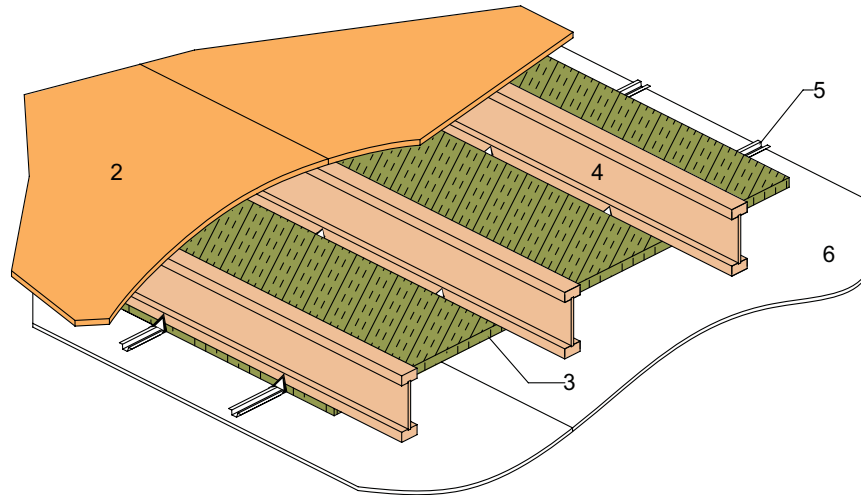

1. **Floor Topping (optional, not shown):** Gypsum concrete, lightweight or normal concrete topping.
2. **Floor Sheathing:** Minimum 23/32 inch thick tongue-and-groove wood sheathing (Exposure 1). Installed per code requirements with minimum 8d common nails.
3. **Insulation:** Minimum 1 inch thick mineral wool insulation batts – 6 pcf (nominal), with width equal to the on-center spacing of the I-joists. Batts installed on top of furring channels and under bottom flange of I-joists with the sides butted against support clips. Abutted ends of batts centered over furring channels with batts tightly butted at all joints.
4. **Structural Members:** Wood I-joists spaced a maximum of 24 inches on center.
 - Minimum I-joist flange depth: 1-1/2 inches
 - Minimum I-joist web thickness: 3/8 inch
 - Minimum I-joist flange area: 3.45 inches²
 - Minimum I-joist depth: 9-1/4 inches

See ASTM D 5055-07 for qualification requirements.
5. **Furring Channels:** Minimum 0.019 inch thick galvanized steel hat-shaped furring channels, attached perpendicular to I-joists spaced 24 inches on center. At channel splices, adjacent pieces overlapped a minimum of 6 inches and tied with a double strand of No. 18 gage galvanized steel wire at each end of the overlap. Channels secured to I-joists with Simpson Type CSC support clips at each intersection with the I-joists. Clips nailed to the side of I-joist bottom flange with one 1-1/2 inch long No. 11 gage nail. A row of furring channel located on each side of wallboard end joints and spaced 2.25 inches from the end joint (4.5 inches on center).
6. **Gypsum Wallboard:** Minimum 1/2 inch thick Type C gypsum wallboard. Wallboard installed with long dimension perpendicular to furring channels and fastened to each channel with minimum 1 inch long Type S drywall screws. Fasteners spaced 12 inches on center in the field of the wallboard, 6 inches on center at wallboard end joints, and 3/4 inches from panel edges and ends. End joints of wallboard staggered. For staggered wallboard end joints, furring channels extend a minimum of 6 inches beyond each end of the joint.
7. **Finish System (not shown):** Face layer joints covered with tape and coated with joint compound. Screw heads covered with joint compound.

Fire Test conducted at Underwriter’s Laboratories, Inc.
Third Party Witness: Underwriter’s Laboratories, Inc.

May 11, 1983
Report No: UL R10371-1

STC and IIC Sound Ratings for Listed Assembly

Without Gypsum Concrete				With Gypsum Concrete			
Cushioned Vinyl		Carpet & Pad		Cushioned Vinyl		Carpet & Pad	
STC	IIC	STC	IIC	STC	IIC	STC	IIC
-	-	46	68	51	47	50	73

^a This assembly may also be used in a fire-rated roof/ceiling application, but only when constructed exactly as described.

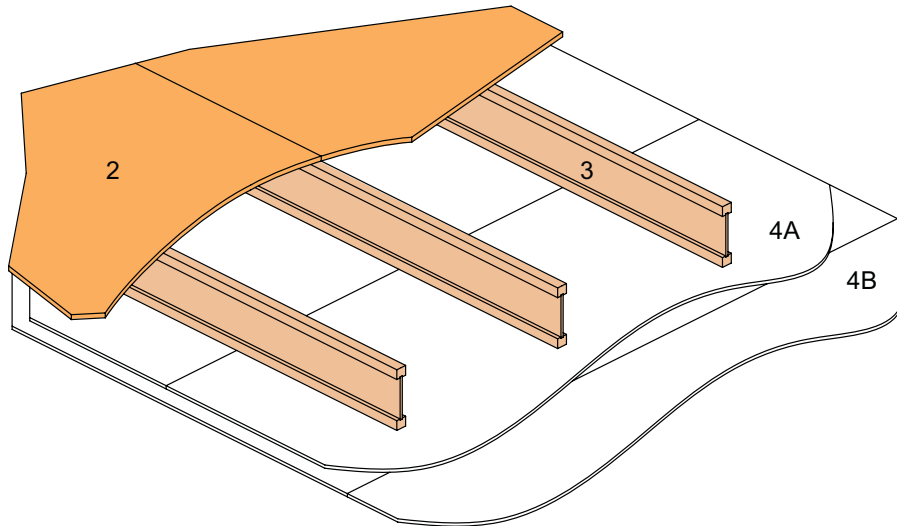
WIJ-1.5 One-Hour Fire-Resistive Ceiling AssemblyFloor^a/Ceiling - 100% Design Load - 1 Hour Rating - ASTM E 119 / NFPA 251

1. **Floor Topping (optional, not shown):** Gypsum concrete, lightweight or normal concrete topping.
2. **Floor Sheathing:** Minimum 23/32 inch thick tongue-and-groove wood sheathing (Exposure 1). Installed per code requirements with minimum 8d common nails.
3. **Structural Members:** Wood I-joists spaced a maximum of 24 inches on center.

Minimum I-joist flange depth: 1-1/2 inches	Minimum I-joist flange area: 2.25 inches ²
Minimum I-joist web thickness: 3/8 inch	Minimum I-joist depth: 9-1/4 inches

See ASTM D 5055-07 for qualification requirements.
4. **Gypsum Wallboard:** Two layers of minimum 1/2 inch Type C gypsum wallboard attached with the long dimension perpendicular to the I-joists as follows:
 - 4a. **Wallboard Base Layer:** Base layer of wallboard attached to bottom flange of I-joists using 1 inch Type S drywall screws at 12 inches on center. End joints of wallboard centered on bottom flange of the I-joist and staggered.
 - 4b. **Wallboard Face Layer:** Face layer of wallboard attached to bottom flange of I-joists through base layer using 1-5/8 inch Type S drywall screws spaced 12 inches on center on intermediate joists and 8 inches on center at end joints. Edge joints of wallboard face layer offset 24 inches from those of base layer. End joints centered on bottom flange of I-joists and offset a minimum of 48 inches from those of base layer. Additionally, wallboard face layer attached to base layer with 1-1/2 inch Type G drywall screws spaced 8 inches on center with a 4" stagger, placed 6 inches from face layer end joints.
5. **Finish System (not shown):** Face layer joints covered with tape and coated with joint compound. Screw heads covered with joint compound.

Fire Test conducted at NGC Testing Services, Inc

Report No. FC-687 January 25, 2007

STC and IIC Sound Ratings for Listed Assembly

Without Gypsum Concrete				With Gypsum Concrete			
Cushioned Vinyl		Carpet & Pad		Cushioned Vinyl		Carpet & Pad	
STC	IIC	STC	IIC	STC	IIC	STC	IIC
-	-	-	-	-	-	49 ^b	55 ^b

^a This assembly may also be used in a fire-rated roof/ceiling application, but only when constructed exactly as described.^b STC and IIC values estimated by David L. Adams Associates, Inc.

WIJ-1.6 One-Hour Fire-Resistive Ceiling Assembly

Floor^a/Ceiling - 100% Design Load - 1 Hour Rating - ASTM E 119 / NFPA 251

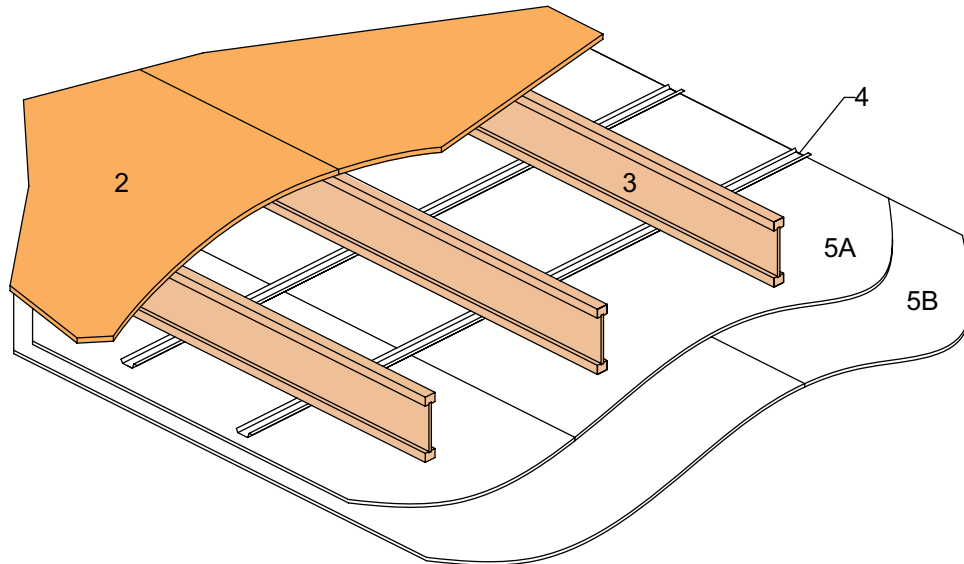

1. **Floor Topping (optional, not shown):** Gypsum concrete, lightweight or normal concrete topping.
2. **Floor Sheathing:** Minimum 23/32 inch thick tongue-and-groove wood sheathing (Exposure 1). Installed per code requirements with minimum 8d common nails.
3. **Structural Members:** Wood I-joists spaced a maximum of 24 inches on center.
 Minimum I-joist flange depth: 1-5/16 inches Minimum I-joist flange area: 1.95 inches²
 Minimum I-joist web thickness: 3/8 inch Minimum I-joist depth: 9-1/2 inches
 See ASTM D 5055-07 for qualification requirements.
4. **Resilient Channels^b:** Minimum 0.019 inch thick galvanized steel resilient channel attached perpendicular to the bottom flange of the I-joists with one 1-1/4 inch drywall screw. Channels spaced a maximum of 16 inches on center [24 inches on center when I-joists are spaced a maximum of 16 inches on center].
5. **Gypsum Wallboard:** Two layers of minimum 1/2 inch Type X gypsum wallboard attached with the long dimension perpendicular to the resilient channels as follows:
 - 5a. **Wallboard Base Layer:** Base layer of wallboard attached to resilient channels using 1-1/4 inch Type S drywall screws at 12 inches on center.
 - 5b. **Wallboard Face Layer:** Face layer of wallboard attached to resilient channels through base layer using 1-5/8 inch Type S drywall screws spaced 12 inches on center. Edge joints of wallboard face layer offset 24 inches from those of base layer. Additionally, wallboard face layer attached to base layer with 1-1/2 inch Type G drywall screws spaced 8 inches on center, placed 1-1/2 inches from face layer end joints.
6. **Finish System (not shown):** Face layer joints covered with tape and coated with joint compound. Screw heads covered with joint compound.

Fire Test conducted at National Research Council of Canada Report No. A-4440.1 June 24, 1997

STC and IIC Sound Ratings for Listed Assembly							
Without Gypsum Concrete				With Gypsum Concrete			
Cushioned Vinyl		Carpet & Pad		Cushioned Vinyl		Carpet & Pad	
STC	IIC	STC	IIC	STC	IIC	STC	IIC
-	-	54	68	-	-	58 ^c	55 ^c

^a This assembly may also be used in a fire-rated roof/ceiling application, but only when constructed exactly as described.

^b Direct attachment of gypsum wallboard in lieu of attachment to resilient channels is typically deemed acceptable. When gypsum wallboard is directly attached to the I-joists, the wallboard should be installed with long dimension perpendicular to the I-joists and sound ratings for WIJ-1.5 should be used.

^c STC and IIC values estimated by David L. Adams Associates, Inc

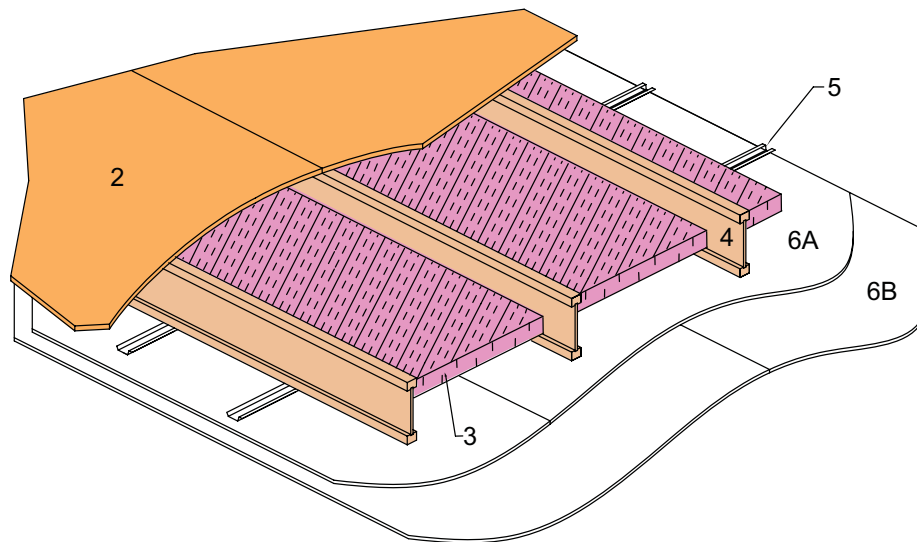
WIJ-1.7 One-Hour Fire-Resistive Ceiling AssemblyFloor^a/Ceiling - 100% Design Load - 1 Hour Rating - ASTM E 119 / NFPA 251

1. **Floor Topping (optional, not shown):** Gypsum concrete, lightweight or normal concrete topping.
2. **Floor Sheathing:** Minimum 23/32 inch thick tongue-and-groove wood sheathing (Exposure 1). Installed per code requirements with minimum 8d common nails.
3. **Insulation:** Fiberglass insulation placed between I-joists supported by the resilient channels.
4. **Structural Members:** Wood I-joists spaced a maximum of 24 inches on center.

Minimum I-joist flange depth: 1-1/2 inches	Minimum I-joist flange area: 2.25 inches ²
Minimum I-joist web thickness: 3/8 inch	Minimum I-joist depth: 9-1/2 inches

See ASTM D 5055-07 for qualification requirements.
5. **Resilient Channels:** Minimum 0.019 inch thick galvanized steel resilient channel attached perpendicular to the bottom flange of the I-joists with one 1-1/4 inch drywall screw. Channels spaced a maximum of 16 inches on center [24 inches on center when I-joists are spaced a maximum of 16 inches on center].
6. **Gypsum Wallboard:** Two layers of minimum 1/2 inch Type X gypsum wallboard attached with the long dimension perpendicular to the resilient channels as follows:
 - 6a. **Wallboard Base Layer:** Base layer of wallboard attached to resilient channels using 1-1/4 inch Type S drywall screws at 12 inches on center.
 - 6b. **Wallboard Face Layer:** Face layer of wallboard attached to resilient channels through base layer using 1-5/8 inch Type S drywall screws spaced 12 inches on center. Edge joints of wallboard face layer offset 24 inches from those of base layer. Additionally, wallboard face layer attached to base layer with 1-1/2 inch Type G drywall screws spaced 8 inches on center, placed 1-1/2 inches from face layer end joints.
7. **Finish System (not shown):** Face layer joints covered with tape and coated with joint compound. Screw heads covered with joint compound.

Fire Test conducted at National Research Council of Canada Report No. A-4219.13.2 March 23, 1998

STC and IIC Sound Ratings for Listed Assembly

Without Gypsum Concrete				With Gypsum Concrete			
Cushioned Vinyl		Carpet & Pad		Cushioned Vinyl		Carpet & Pad	
STC	IIC	STC	IIC	STC	IIC	STC	IIC
59	50	55 ^b	68 ^b	65	51	63 ^b	65 ^b

^a This assembly may also be used in a fire-rated roof/ceiling application, but only when constructed exactly as described.^b STC and IIC values estimated by David L. Adams Associates, Inc

WIJ-2.1 Two-Hour Fire-Resistive Ceiling Assembly

Floor^a/Ceiling - 100% Design Load - 2 Hour Rating - ASTM E 119 / NFPA 251

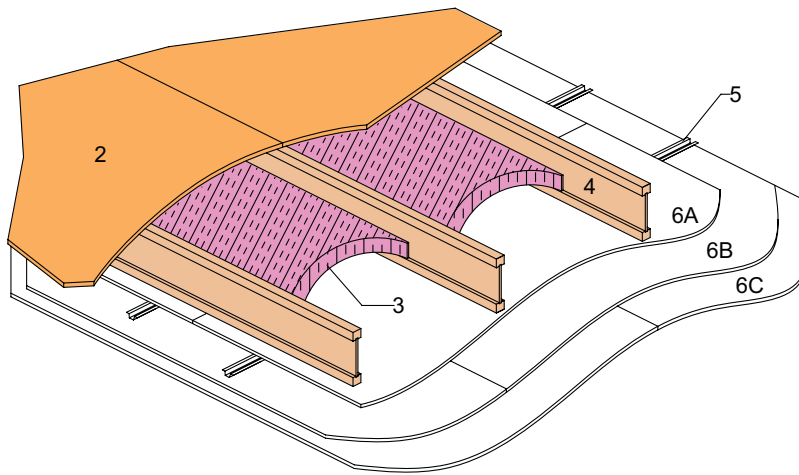

1. **Floor Topping (optional, not shown):** Gypsum concrete, lightweight or normal concrete topping.
2. **Floor Sheathing:** Minimum 23/32 inch thick tongue-and-groove wood sheathing (Exposure 1). Installed per code requirements.
3. **Insulation:** Minimum 3-1/2 inch thick unfaced fiberglass insulation fitted between I-joists supported by stay wires spaced 12 inches on center.
4. **Structural Members:** Wood I-joists spaced a maximum of 24 inches on center.
 - Minimum I-joist flange depth: 1-1/2 inches
 - Minimum I-joist web thickness: 3/8 inch
 - Minimum I-joist flange area: 2.25 inches²
 - Minimum I-joist depth: 9-1/4 inches
5. **Furring Channels:** Minimum 0.0179 inch thick galvanized steel hat-shaped furring channels, attached perpendicular to I-joists using 1-5/8 inch long drywall screws. Furring channels spaced 16 inches on center (furring channels used to support the second and third layers of gypsum wallboard).
6. **Gypsum Wallboard:** Three layers of minimum 5/8 inch Type C gypsum wallboard as follows:
 - 6a. **Wallboard Base Layer:** Base layer of wallboard attached to bottom flange of I-joists using 1-5/8 inch Type S drywall screws at 12 inches on center with the long dimension of wallboard perpendicular to I-joist. End joints of wallboard centered on bottom flange of the I-joist and staggered from end joints in adjacent sheets.
 - 6b. **Wallboard Middle Layer:** Middle layer of wallboard attached to furring channels using 1 inch Type S drywall screws spaced 12 inches on center with the long dimension of wallboard perpendicular to furring channels. End joints staggered from end joints in adjacent sheets.
 - 6c. **Wallboard Face Layer:** Face layer of wallboard attached to furring channels through middle layer using 1-5/8 inch Type S drywall screws spaced 8 inches on center. Edge joints of face layer of wallboard offset 24 inches from those of middle layer. End joints of face layer of wallboard staggered with respect to the middle layer.
7. **Finish System (not shown):** Face layer joints covered with tape and coated with joint compound. Screw heads covered with joint compound.

See ASTM D 5055-07 for qualification requirements.

Fire Test conducted at Gold Bond Building Products Research Center December 16, 1992
 Third Party Witness: PFS Corporation Report No: #92-56

STC and IIC Sound Ratings for Listed Assembly

Without Gypsum Concrete				With Gypsum Concrete			
Cushioned Vinyl		Carpet & Pad		Cushioned Vinyl		Carpet & Pad	
STC	IIC	STC	IIC	STC	IIC	STC	IIC
-	-	49 ^b	54 ^b	52 ^b	46 ^b	52 ^b	60 ^b

^a This assembly may also be used in a fire-rated roof/ceiling application, but only when constructed exactly as described.

^b STC and IIC values estimated by David L. Adams Associates, Inc