



SIMPSON

Strong-Tie®

®



## INSTALLER'S POCKET GUIDE

## GUÍA DE BOLSILLO PARA EL INSTALADOR

S-C-INSTALL14

The information in this guide is intended to show contractors how our products should be installed. It is not intended for use by Designers. Designers should refer to the current Simpson Strong-Tie® **Wood Construction Connectors** catalog for loads and other critical design information.

La información de esta guía tiene la intención de mostrarles a los contratistas como deben instalar nuestros productos. No está diseñada para que la usen los diseñadores. Los diseñadores deben referirse al catálogo actual de **Conectores para Construcciones de Madera** para determinar las cargas y demás información crítica para el diseño.



## QUESTIONS? ¿PREGUNTAS? (800) 999-5099

This guide is intended to provide a quick reference tool to aid in the correct installation of Simpson Strong-Tie® products. It is important that users follow any installation guidelines specified by the Designer and refer to the current Simpson Strong-Tie **Wood Construction Connectors** catalog for other important installation information.

This guide is not intended for use as a design tool by Designers. Please see the current Simpson Strong-Tie **Wood Construction Connectors** catalog for complete technical data and other important design information.

Esta guía tiene como objetivo servir como herramienta de referencia rápida para facilitar la correcta instalación de los productos Simpson Strong-Tie®. Es importante que los usuarios sigan todas las pautas de instalación especificadas por el diseñador y consulten el catálogo de **Conectores para Construcciones de Madera** de Simpson Strong-Tie para obtener más información importante sobre la instalación.

Esta guía no está ideada para ser usada como herramienta de diseño por parte de diseñadores. Consulte el catálogo de **Conectores para Construcciones de Madera** de Simpson Strong-Tie para conocer todos los datos técnicos y otros datos importantes de diseño.

A35 .....	17	H1 .....	40-41
AB .....	18-19	H2.5A.....	42
ABA.....	20	H2.5T .....	43
ABU.....	21-23	H10 .....	44-45
Adhesive Anchoring/ Anclaje Adhesivo ....	24-25	HDA .....	46-47
BC .....	26	HDQ8 .....	48
BCS2-2/4.....	27	HDU .....	49
BC40 .....	28	HETA .....	50-51
BPS-LBPS .....	29	HPAHD22.....	52-53
CB .....	30-31	HSS.....	54-55
CBQ.....	32	HTT .....	56
CBSQ .....	33	HTU.....	57
CC .....	34	HUS .....	58-59
CCQ.....	35	ITS .....	60-61
CS/CMST14 .....	36-37	ITT .....	62-63
DTC.....	38	IUS.....	64-65
GBC.....	39	LGT2 .....	66-67

# Index/Indexe

LS .....	68	SP .....	92
LSSU .....	69	SP4 .....	93
LSTA .....	70	SSP .....	94
LTHJR .....	71	SSTB .....	95
LTP4/LTP5 .....	72	STHD .....	96
LUCZ .....	73	STC .....	97
LUS .....	74-75	SUR/L .....	98-99
MA .....	76	THA .....	100-101
MAB .....	77-79	THJA .....	102
MASA/MAS .....	80-83	THJU .....	103
MST .....	84-85	TSB .....	104-105
PB .....	86	Titen HD® .....	106-107
PHD .....	87	TWB .....	108-109
PSPN .....	88	VGT .....	110-111
RBC .....	89	VPA .....	112-113
RSP4 .....	90		
SB .....	91		

# Connectors: Types of Nail Holes

## Conectores: Tipos de Agujeros de Clavo

---

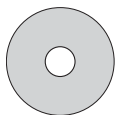

**ROUND  
REDONDO**

- **Purpose:**  
To fasten a connector.
  - **Fill Requirements:**  
Always fill, unless otherwise noted.
  - **Propósito:**  
Para fijar un conector.
  - **Requisitos para Llenar:**  
Llénelo siempre, salvo que se indique lo contrario.
- 

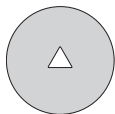

**TRIANGULAR**

- **Purpose:**  
To increase a connector's strength or to achieve MAX strength.
  - **Fill Requirements:**  
When the Designer specifies "Max" nailing.
  - **Propósito:**  
Para aumentar la fuerza de un conector o para lograr una fuerza máxima.
  - **Requisitos para Llenar:**  
Llénelo cuando el diseñador lo especifica clavado "Máx."
- 

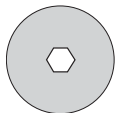

**HEXAGONAL**

- **Purpose:**  
To fasten a connector to concrete or masonry.
- **Fill Requirements:**  
Always fill when fastening a connector to concrete or fastening a connector with masonry screws.

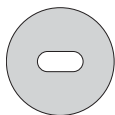

**OBROUND  
ALARGADO**

- **Purpose:**  
To make fastening a connector in a tight location easier.
- **Fill Requirements:**  
Always fill, unless otherwise noted.
- **Propósito:**  
Para fijar un conector en una locación apretada con el fin de facilitar el trabajo.
- **Requisitos para Llenar:**  
Llénelo siempre, salvo que se indique lo contrario.

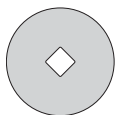

**DIAMOND  
DIAMANTE**

- **Purpose:**  
To temporarily fasten a connector to make installing it easier.
- **Fill Requirements:**  
None.
- **Propósito:**  
Para fijar temporalmente un conector, con el propósito de facilitar su instalación.
- **Requisitos para Llenar:**  
Ninguno.

- **Propósito:**  
Para fijar un conector a concreto o mampostería.
- **Requisitos para Llenar:**  
Siempre llénelo al fijar un conector a concreto o al fijar un conector con tornillos de mampostería.

# Connectors: Types of Nail Holes

## Conectores: Tipos de Agujeros de Clavo

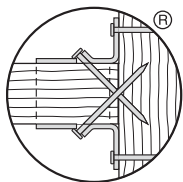

### DOUBLE-SHEAR NAILING

### CLAVADO DE DOBLE PENETRACIÓN

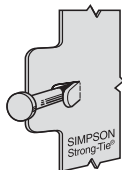
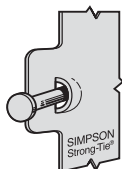

- **Purpose:**  
Installed into the joist and header, distributing the load through two points on each joist nail for greater strength. Must use full length nail.
- **Fill Requirements:**  
Always fill, and make sure you use the right nail.
- **Propósito:**  
Para lograr mayor fuerza, los clavos penetran a la vigueta y la viga cabezal, así distribuyendo la carga entre las dos puntas de cada clavo.
- **Requisitos para Llenar:**  
Llénelo siempre, y asegúrese de usar el clavo correcto.



**DO NOT use short (1½") nails for double-shear nailing.**

**NO usen los clavos cortos de 1½" para uso de doble penetración.**

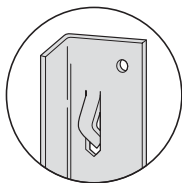

### 8 SPEED PRONGS

- **Purpose:**  
To temporarily position and secure the connector for easier and faster installation.
- **Fill Requirements:**  
None.

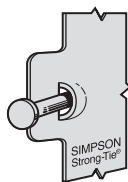

**DOME NAILING**

*U.S. Patent No.  
5,603,580*

**CLAVADO CON  
CÚPULA**

*Patente de EE.UU.  
No. 5,603,580*

- **Purpose:**

To guide the nail into the joist and header at a 45° angle.

- **Fill Requirements:**

Always fill, and make sure you use the right nail.

- **Propósito:**

Con este dispositivo se guían el clavo en la vigueta y la viga cabezal en ángulo de 45°.

- **Requisitos para Llenar:**

Llénelo siempre, y asegúrese de usar el clavo correcto.

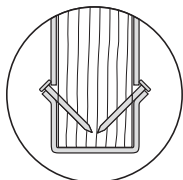
**POSITIVE-ANGLE  
NAILING****CLAVADO  
EFECTIVO  
EN ÁNGULO**

- **Purpose:**

Provided when wood splitting may occur, and to speed installation.

- **Fill Requirements:**

Always fill, and make sure you use the right nail.

- **Propósito:**

Se usa cuando la madera puede rajarse o abrirse y con el propósito hacer más rápida la instalación.

- **Requisitos para Llenar:**

Llénelo siempre, y asegúrese de usar el clavo correcto.

**DIENTES RÁPIDOS**

- **Propósito:**

Se usan para colocar el conector y fijarlo temporalmente, con el fin de facilitar y hacer más rápida su instalación.

- **Requisitos para Llenar:**

Ninguno.

# Fasteners/Clavos

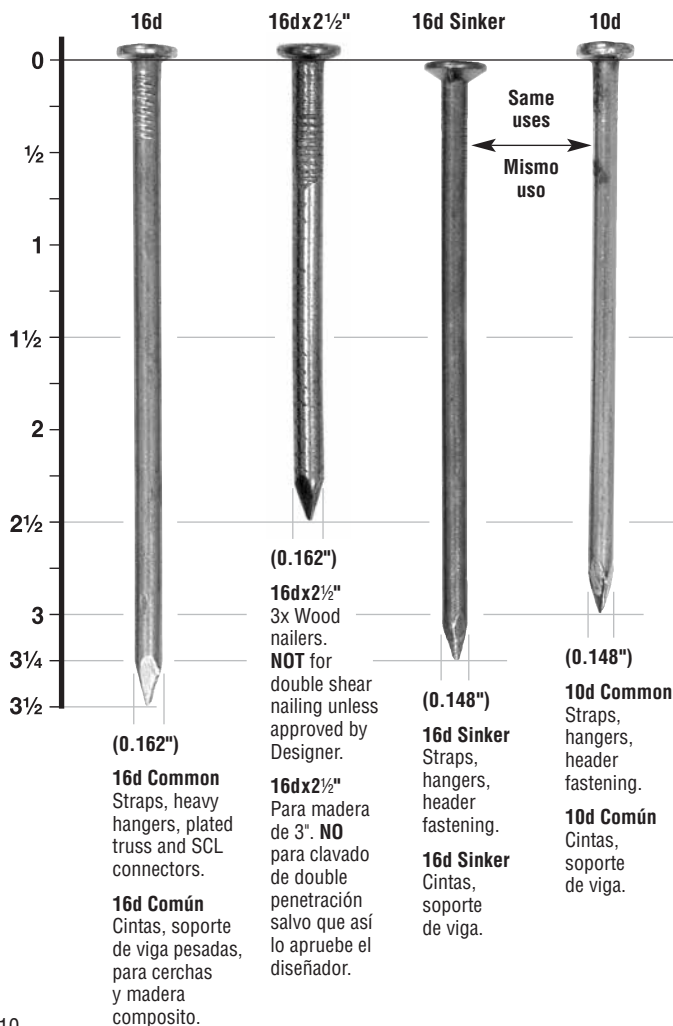

10dx1½"



(0.148")

10dx1½"

2x Joist nailing.

**Caution:** Load reduction if used as header nails.

**Galvanized nail shown.**

10dx1½"

Clavado de vigas 2x.

**Cuidado:** Reduce la capacidad si se usa en la viga cabezal.

**Se muestra un clavo galvanizado.**

8d



(0.131")

8d Common Rafter ties.

8d Común "Clips" de huracán.

8dx1½"



(0.131")

8dx1½"

Light duty framing anchors and some rafter ties.

**Galvanized nail shown.**

8dx1½"

Conectores ligeros y "clips" de huracán.

**Se muestra un clavo galvanizado.**

0

½

1

1½

2

2½

3

¾

¾

When using stainless-steel connectors, use stainless-steel fasteners. When using ZMAX®/hot-dip galvanized connectors, use fasteners galvanized per ASTM A153.

Al usar los conectores del acero inoxidable, utilice los sujetadores del acero inoxidable. Al usar conectores ZMAX®/HDG galvanizados, utilicen los sujetadores galvanizados por ASTM A153.

# Fasteners/Clavos

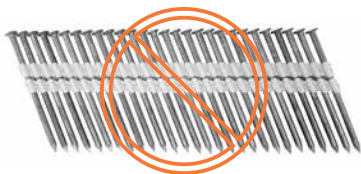

**Framing nail-gun nails can only be used if:**

1. Correct diameter and length
2. Correct quantity is installed
3. Driven with a hole location tool (*finds the hole*) or by hand

**NOTE:** .121 may NOT be used to replace 10d or 16d nails.

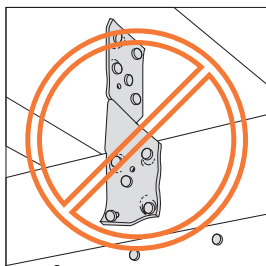

**DO NOT OVERDRIVE  
NO SHOOTING-THRU  
CONNECTORS**

**NO SE METE  
DEMASIADO  
NO SE PUEDE  
HACER AGUJEROS  
CON MAQUINA**

**Sólo se pueden utilizar clavos estructurales para pistola si:**

1. Tengan diámetro y tamaño correcto
2. Se instala la cantidad correcta
3. Usan maquina que encuentre el agujero, o se clavan a mano

**NOTA:** NO se pueden utilizar clavos 121 como sustitutos de clavos 10d o 16d.



**Common screws may NOT be used to replace NAILS in connectors.**

**NO se puede usar tornillos comunes en vez de CLAVOS en conectores.**

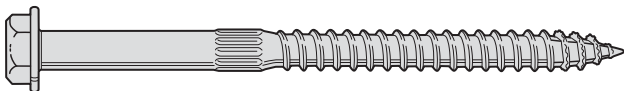

Some connectors install with the Simpson Strong-Tie® Strong-Drive® (SDS) 1/4" structural wood screw.

1. Install with 3/8" hex socket or nut driver
2. Pre-drilling generally not required
3. Do not substitute with lag screws

Algunos conectores se instalan con el tornillo para madera estructural Strong Drive® (SDS) de 1/4" de Simpson Strong-Tie®.

1. Instalar con un destornillador de casquillo hexagonal o de tuercas de 3/8"
2. Generalmente no es necesario efectuar perforaciones previas
3. No sustituir con tirafondos

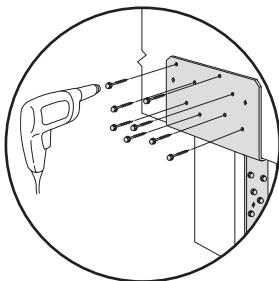

### **MACHINE BOLT**

**Diameter:** 1/2, 5/8, 3/4, 7/8, 1

### **PERNOS**

**Diametro:** 1/2, 5/8, 3/4, 7/8, 1

# General Connector Installation

## Instalación de Conectores en General

### TOP FLANGE HANGERS / SOPORTES CON ALA SUPERIOR

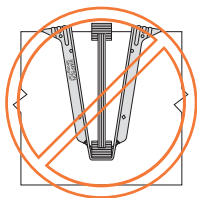

Hanger over-spread  
Soporte demasiado abierto

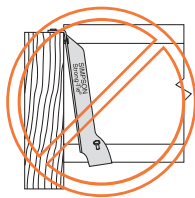

Hanger not plumb  
Soporte fuera de plomo

### WOOD NAILERS / LISTONES CLAVADORES DE MADERA

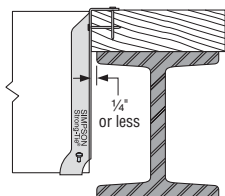

Correct attachment  
Montaje correcto

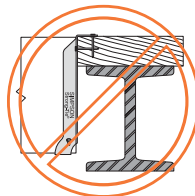

Nailer too wide  
Listón clavador muy ancho

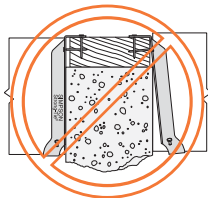

Nailer too narrow  
Listón clavador muy estrecho

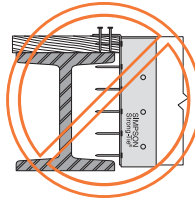

Nailer too thin  
Listón clavador demasiado delgado

## PREVENT ROTATION / EVITAR LA ROTACIÓN

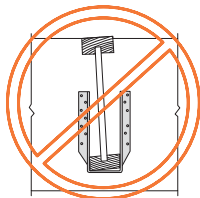

Shorter hanger with no web stiffener results in rotation

Un soporte colgante más corto sin de entramado permitirá la rotación

## TOE-NAILING / CLAVADO EN DIAGONAL

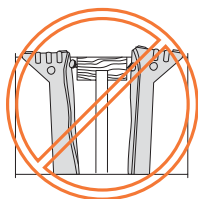

Do not toe nail I-joists before installing top flange or face mount hangers

No clave en ángulo las viguetas 'I' antes de montar los soportes (*con o sin ala superior*)

## POSITIVE ANGLE NAILING CLAVADO EFECTIVO EN ÁNGULO

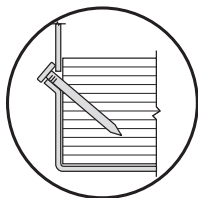

Correct nailing  
approx. 45° angle  
Clavado correcto  
aproximadamente  
a 45°



Nail at wrong angle  
Clavado con un  
ángulo incorrecto

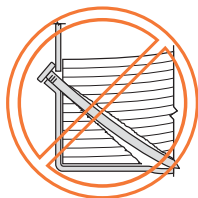

Nail too long  
Clavos demasiado  
largos

# General Connector Installation

## Instalación de Conectores en General

---

### ITS/IUS HANGERS / SOPORTES DE ITS/IUS

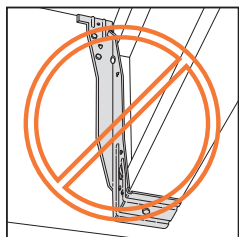

**DO NOT** make your own holes  
**DO NOT** nail bottom chord  
**NO** haga otros orificios para los clavos  
**NO** clave en la viga inferior

---

### DOUBLE SHEAR NAILING

### CLAVADO DE DOBLE PENETRACIÓN

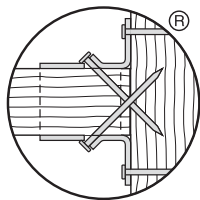

Double-shear nailing must use full length 10d or 16d common nails  
Al trabajar con clavado de doble penetración, se deben emplear clavos comunes 10d o 16d de longitud normal



Shorter nails may not be used as double-shear nails  
No se pueden utilizar clavos más cortos como clavos de doble penetración



# A35

**SIMPSON**  
**Strong-Tie**

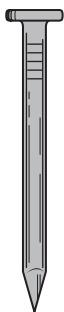
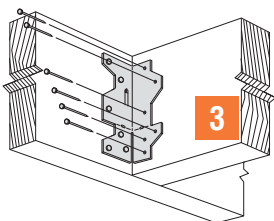
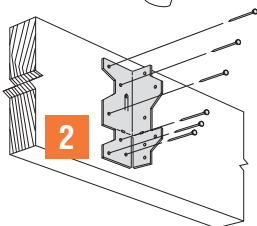
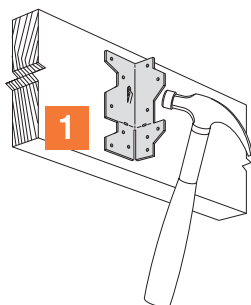
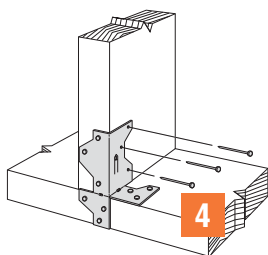
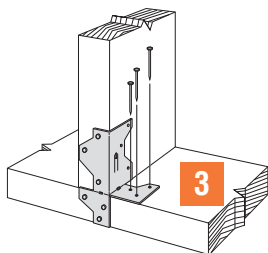
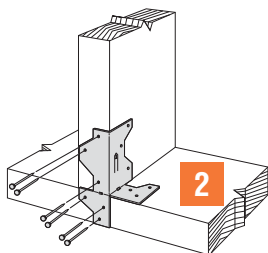
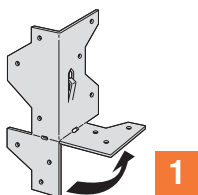

8d x 1 1/2"  
(0.131" x 1 1/2")

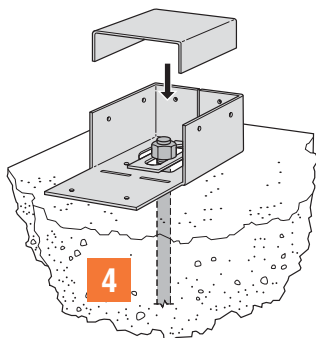
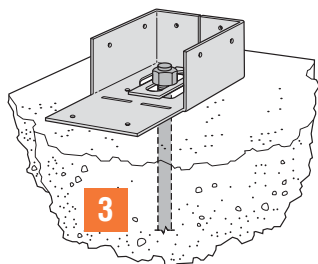
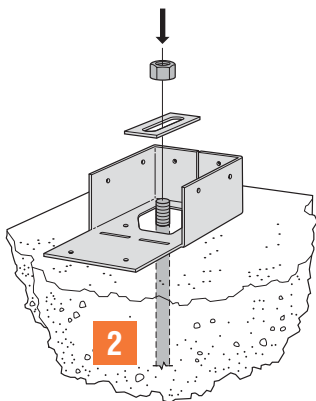
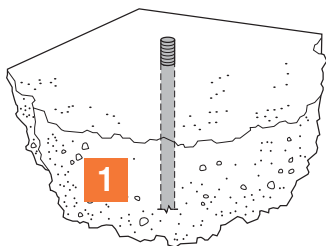

**If using an adhesive anchor, see page 24 for instructions.**

**Si utiliza un anclaje adhesivo, consulte las instrucciones de la página 24.**

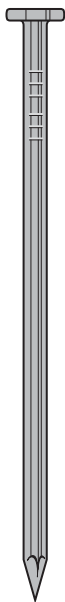
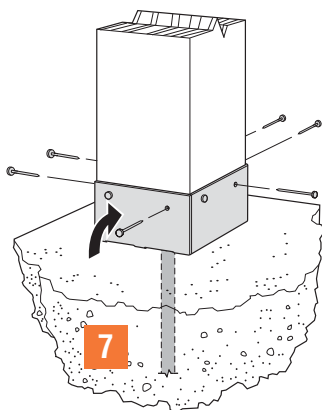
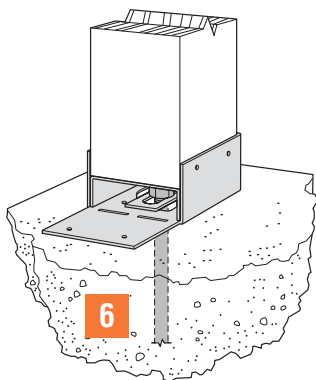
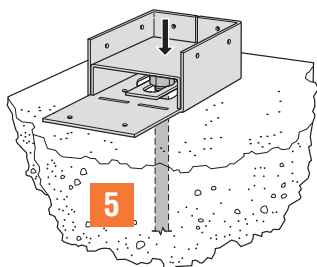

**10d**  
**(0.148" x 3")**

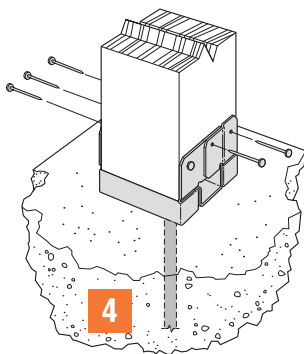
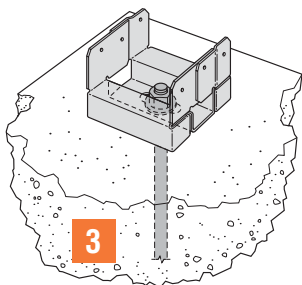
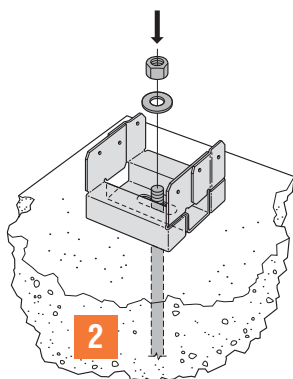
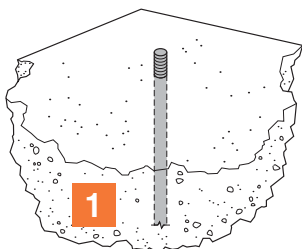

If using an adhesive anchor, see page 24 for instructions.

Si utiliza un anclaje adhesivo, consulte las instrucciones de la página 24.



16d (0.162" x 3½") – ABA46, ABA46R, ABA66, ABA66R

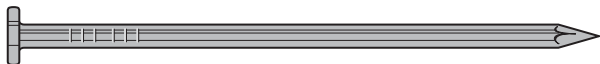

10d (0.148" x 3") – ABA44, ABA44R

# ABU – Nails/Clavos

SIMPSON

Strong-Tie

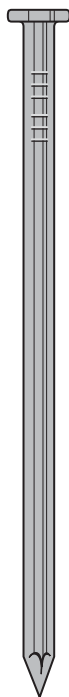
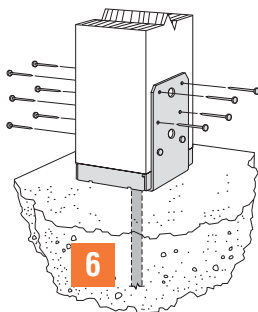
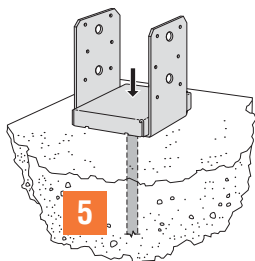
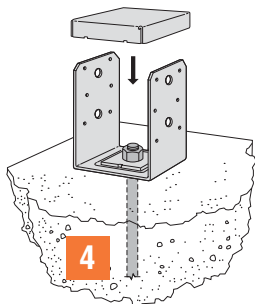
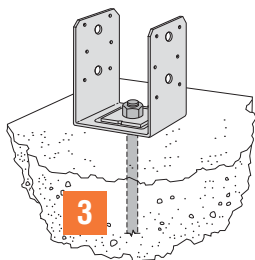
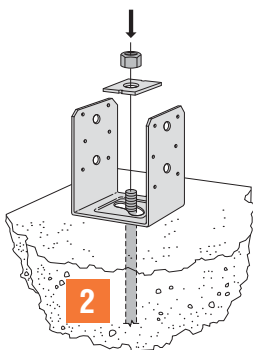
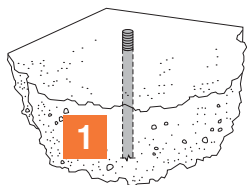

16d

(0.162" x 3 1/2")

If using an adhesive anchor, see page 24 for instructions.

Si utiliza un anclaje adhesivo, consulte las instrucciones de la página 24.

# ABU – Machine Bolts/Pernos

**SIMPSON**  
**Strong-Tie**

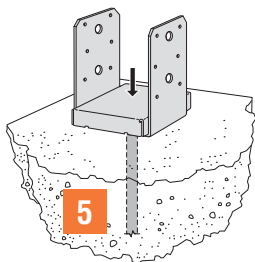
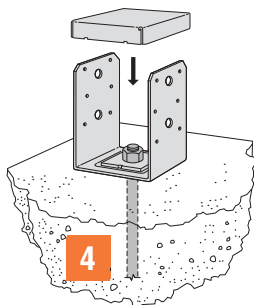
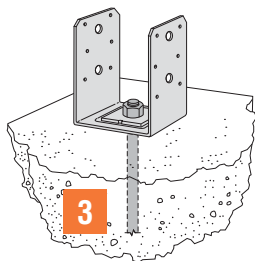
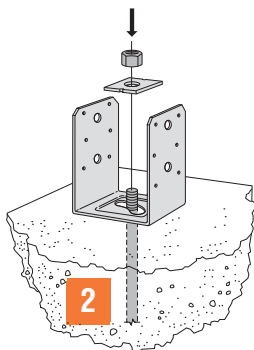
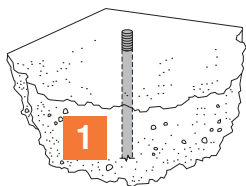

If using an adhesive anchor, see page 24 for instructions.

Si utiliza un anclaje adhesivo, consulte las instrucciones de la página 24.

# ABU – Machine Bolts/Pernos

**SIMPSON**  
**Strong-Tie**

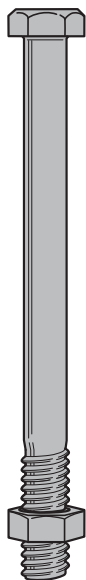
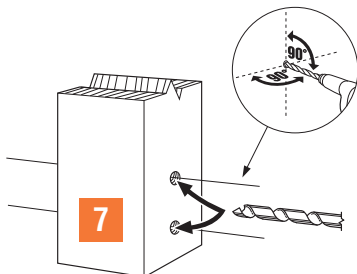
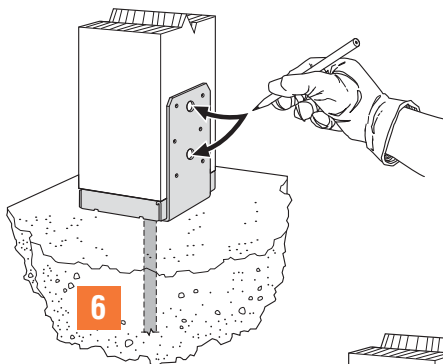

**Machine Bolt**  
**Diameter:  $\frac{1}{2}$ "**

**Length:**

**ABU44/ABU46 =  $4\frac{1}{2}$ "**

**ABU66 =  $6\frac{1}{2}$ "**

**Bolt holes must be a minimum of  $\frac{1}{32}$ " and a maximum of  $\frac{1}{16}$ " larger than bolt diameter.**

**Perno Torneado**

**Diámetro:  $\frac{1}{2}$ "**

**Largo:**

**ABU44/ABU46 =  $4\frac{1}{2}$ "**

**ABU66 =  $6\frac{1}{2}$ "**

**Los orificios para los pernos deben ser al menos  $\frac{1}{32}$ " y como máximo  $\frac{1}{16}$ " más grandes que el diámetro del perno.**

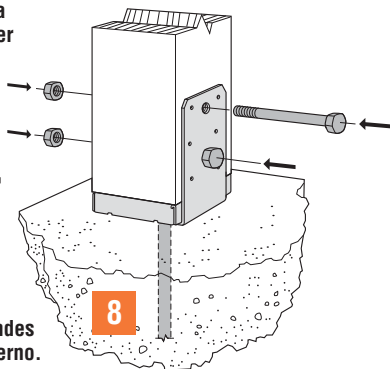

# Adhesive Anchoring

## Anclaje Adhesivo

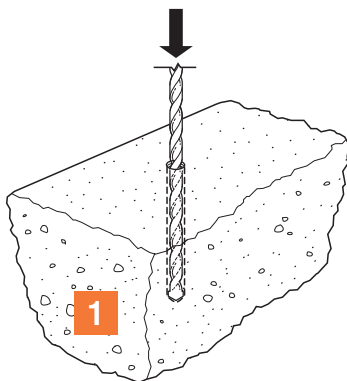

Compressed air  
(80 psi mín.),  
4 seconds (mín.)

Aire comprimido  
(80 psi mín.),  
4 segundos (mín.)

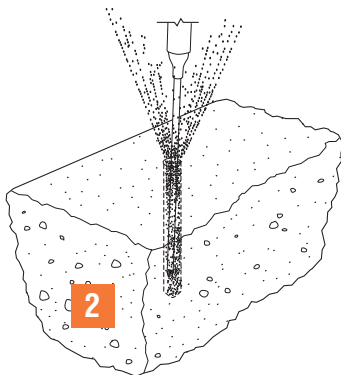

Nylon brush  
4 cycles (mín.)

Cepillo de nailon  
4 ciclos (mín.)

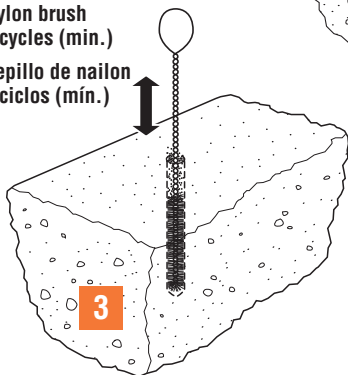



Compressed air (80 psi min.),  
4 seconds (min.)

Aire comprimido (80 psi mín.),  
4 segundos (mín.)

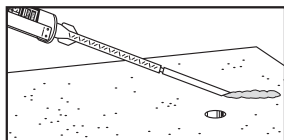
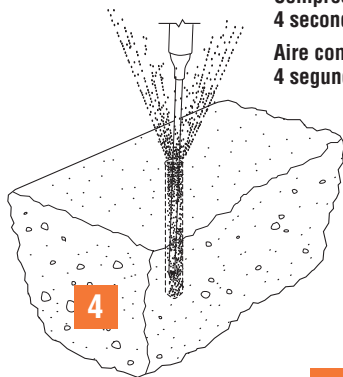

Dispense until uniform color  
Aplique hasta lograr un color  
uniforme

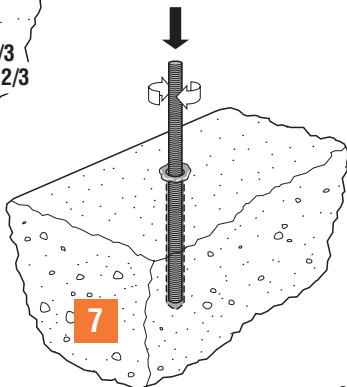
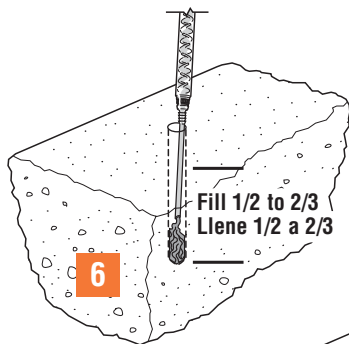

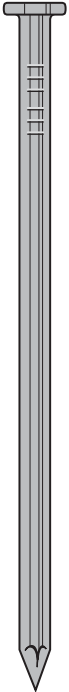

**16d**  
**(0.162" x 3 1/2")**

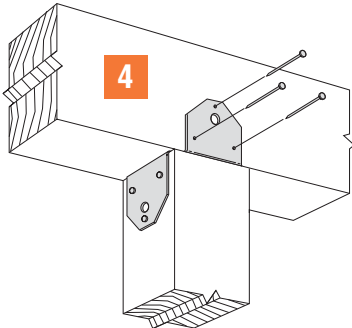
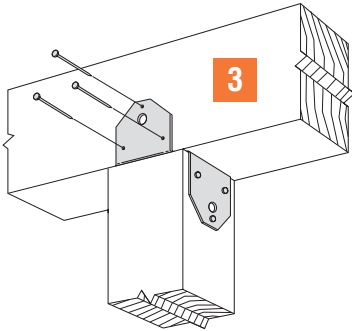
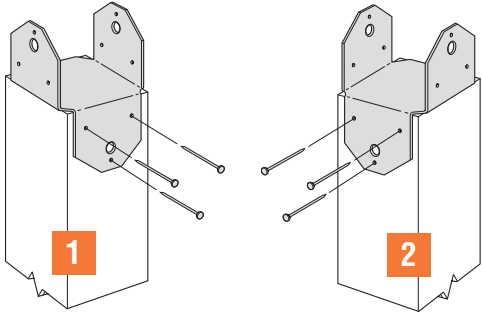

# BCS2-2/4

**SIMPSON**  
**Strong-Tie**

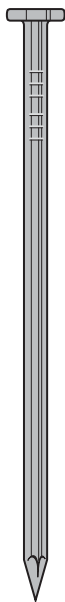

**10d**  
**(0.148" x 3")**

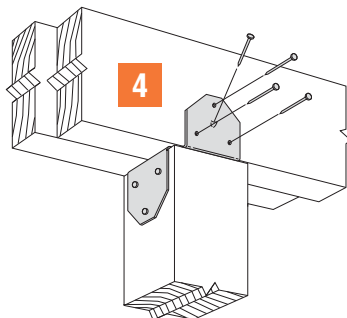
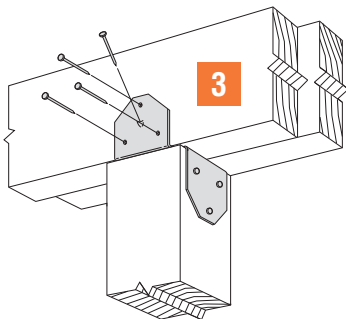
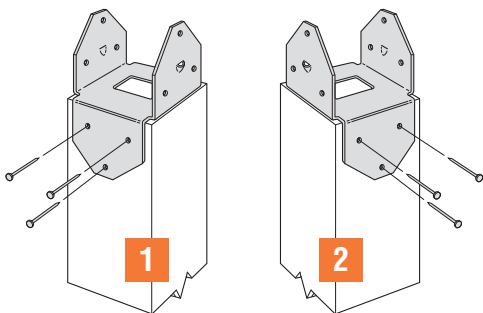

# BC40

**SIMPSON**  
**Strong-Tie**

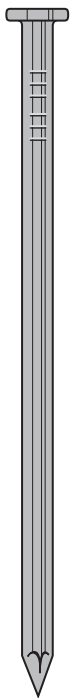

**16d**  
**(0.162" x 3 1/2")**

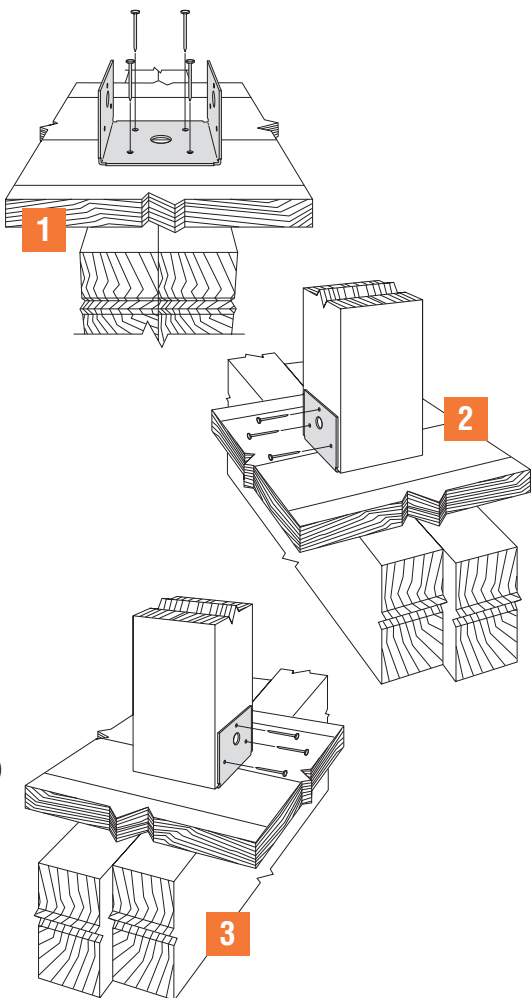

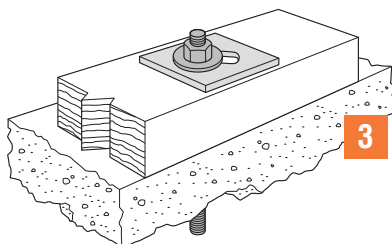
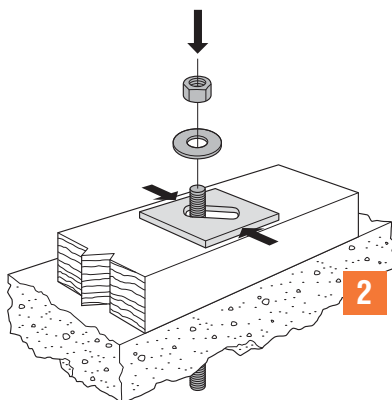
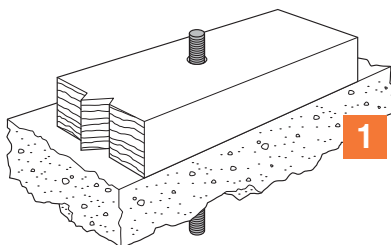

# CB – Machine Bolts/Pernos

**SIMPSON**  
**Strong-Tie**

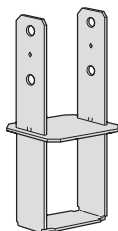

**1**

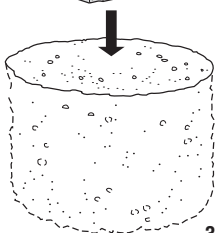

**2**

**3" Side  
cover  
(min.)**  
**Cubierta  
lateral de  
3" (mín.)**

**3" Side  
cover  
(min.)**  
**Cubierta  
lateral de  
3" (mín.)**

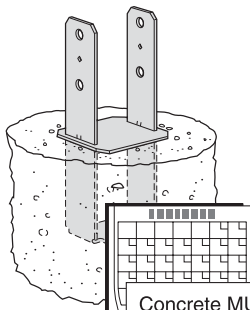

**3**

**Concrete MUST cure**  
**El concreto DEBE curar**

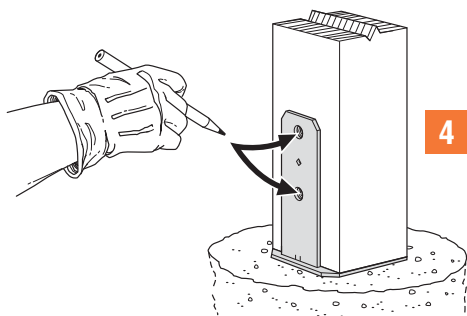

4

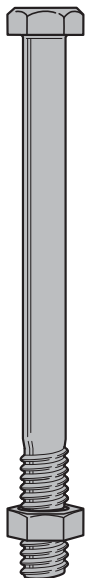

## Machine Bolt Perno

Model No./ N.º de Modelo	Machine Bolt Size/ Tamaño del Perno
CB44	5/8" x 4 1/2"
CB46	5/8" x 4 1/2"
CB48	5/8" x 4 1/2"
CB64	5/8" x 4 1/2"
CB66	5/8" x 6 1/2"
CB68	5/8" x 6 1/2"
CB86	3/4" x 8 1/2"
CB88	3/4" x 8 1/2"
CB1010	3/4" x 10 1/2"
CB1012	3/4" x 10 1/2"
CB1212	3/4" x 11 1/2"

Bolt holes must be a minimum of 1/32" and a maximum of 1/16" larger than bolt diameter.

Los orificios para los pernos deben ser al menos 1/32" y como máximo 1/16" más grandes que el diámetro del perno.

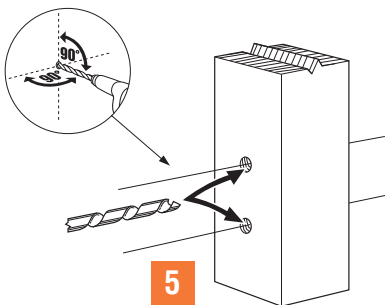

5

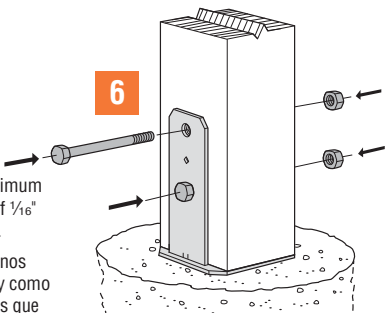

6

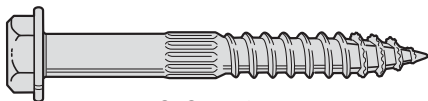
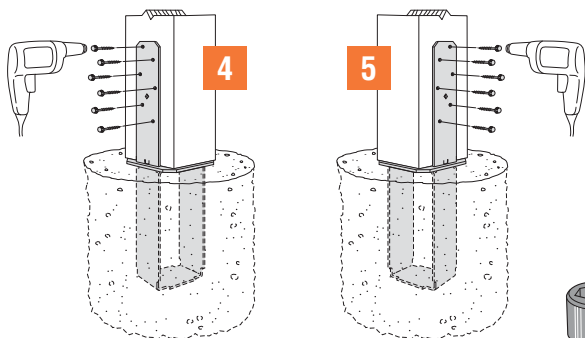
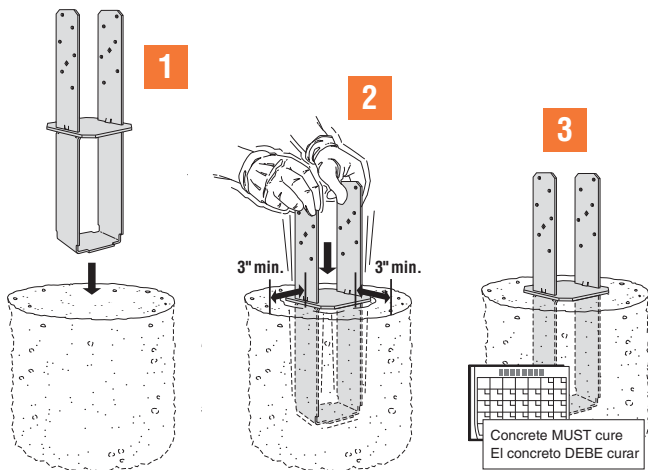

Use 3/8"  
driver

Use un  
destornillador  
de 3/8"

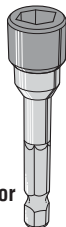



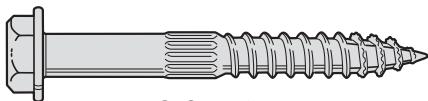
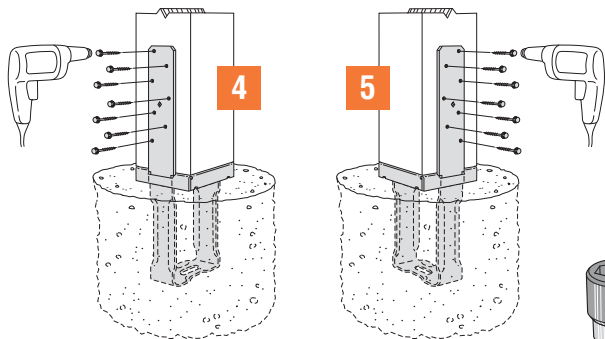
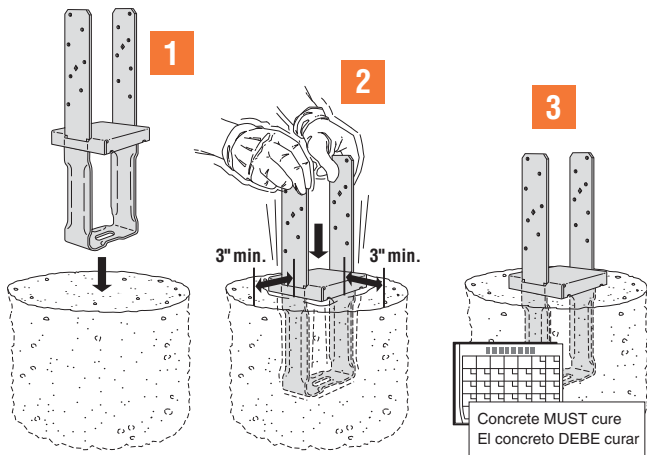

SDS 1/4" x 2"

Use 3/8"  
driver

Use un  
destornillador  
de 3/8"

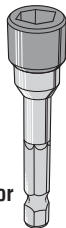

# CC – Machine Bolts/Pernos

**SIMPSON**  
Strong-Tie

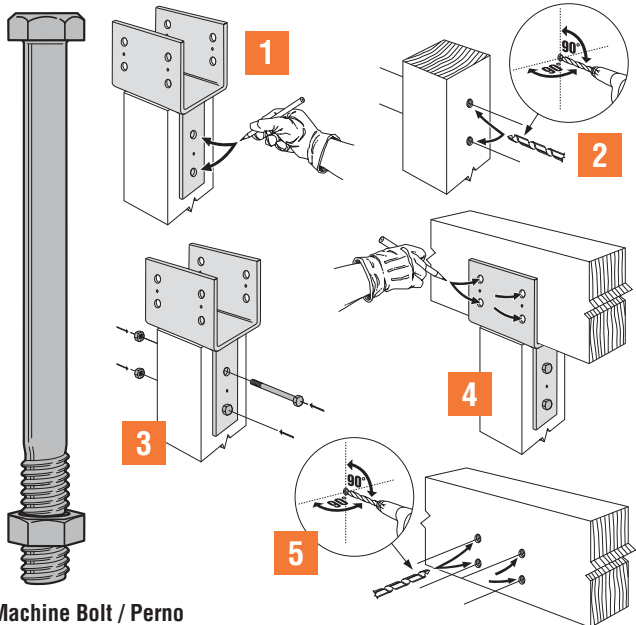

## Machine Bolt / Perno

Beam or Column Width Ancho de Dintel o de Columna	Machine Bolt Size Tamaño del Perno Torneado	
	Diameter Diámetro	Length Longitud
3 1/8"	5/8"	4 1/2"
3 1/2"	5/8"	4 1/2"
5 1/8"	3/4"	6 1/2"
5 1/2"	5/8"	6 1/2"
6 3/4"	3/4"	8"
7"	3/4"	8"
7 1/2"	3/4"	8 1/2"
8 3/4"	3/4"	10"
9 1/2"	3/4"	10 1/2"

Bolt holes must be a minimum of 1/32" and a maximum of 1/16" larger than bolt diameter.

Los orificios para los pernos deben ser al menos 1/32" y como máximo 1/16" más grandes que el diámetro del perno.

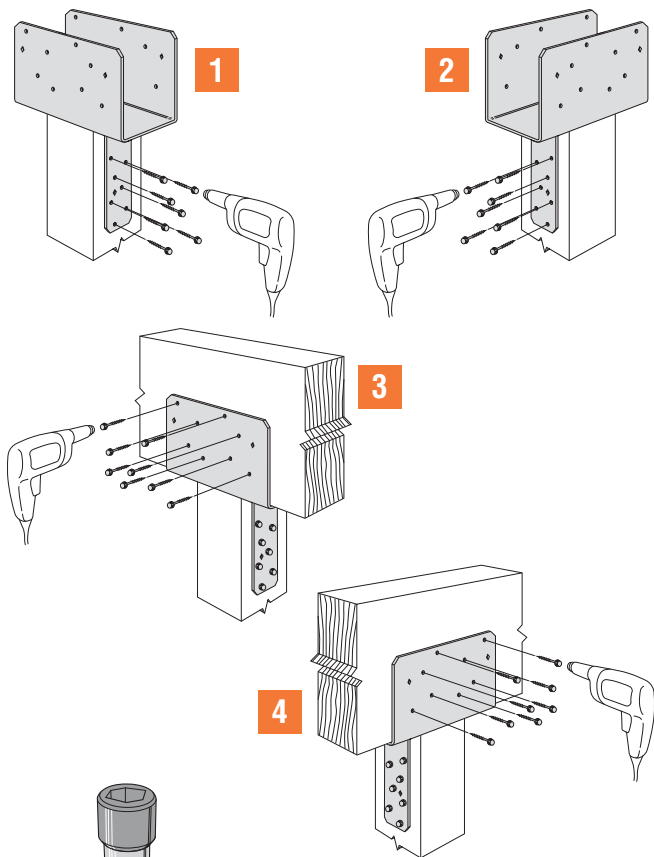

Use  $\frac{3}{8}$ "  
driver

Use un  
destornillador  
de  $\frac{3}{8}$ "

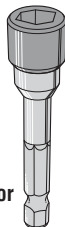

SDS  $\frac{1}{4}$ " x  $2\frac{1}{2}$ "

# CS/CMST14

**SIMPSON**  
**Strong-Tie**

**CS14**  
**Shown**  
**Mostrado**

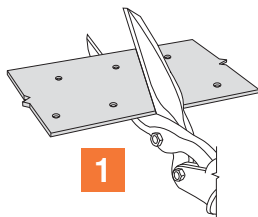

See chart for  
nail selection

Consulte la  
tabla para  
seleccionar  
los clavos

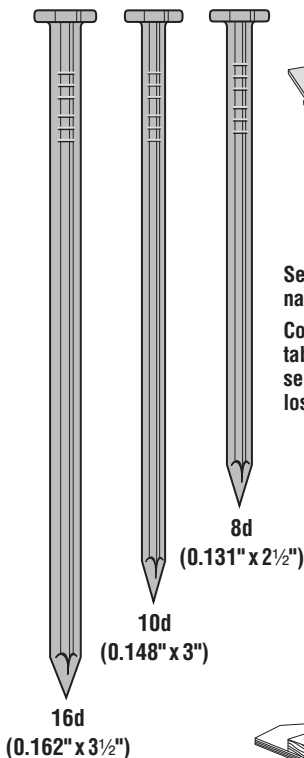
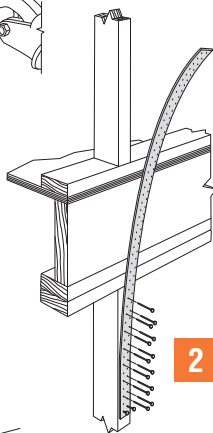

(CMST requires  
minimum 2-2x studs)  
(CMST requiere puntales  
de 2-2x como mínimo)

Provide min. 1 5/8" end  
distance for CS and CMST  
Dejar al menos 1 5/8" y  
distancia para CS y CMST

Equal number of  
specified nails in each end  
Igual cantidad de clavos  
especificados en cada extremo

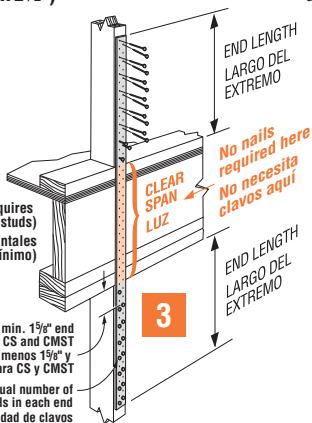

## Across Joists Sobre Varias Viguetas

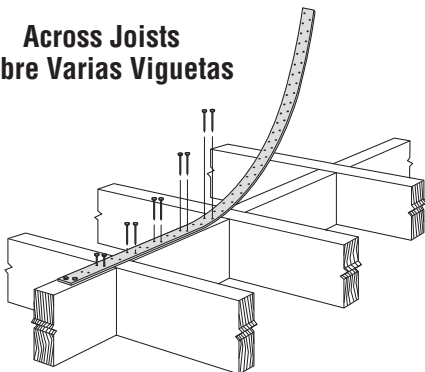

Model/ Modelo	Lumber Species / Especies de Madera					
	Douglas Fir-Larch/Southern Pine			Spruce-Pine-Fir/HemFir		
	End Length/ Largo del Extremo	Cut Length/ Largo a Cortar	Total Fasteners/ Total de Clavos	End Length/ Largo del Extremo	Cut Length/ Largo a Cortar	Total Fasteners/ Total de Clavos
CS14	15"	Clear Span (Luz)+30"	26-10d	16"	Clear Span (Luz)+32"	30-10d
CS14-R	16"	Clear Span (Luz)+32"	30-8d	19"	Clear Span (Luz)+38"	36-8d
CS16	13"	Clear Span (Luz)+26"	22-8d	14"	Clear Span (Luz)+28"	26-8d
CS16-R	11"	Clear Span (Luz)+22"	20-10d	12"	Clear Span (Luz)+24"	22-10d
CS18S	11"	Clear Span (Luz)+22"	18-8d	12"	Clear Span (Luz)+30"	22-8d
CS18S	9"	Clear Span (Luz)+18"	16-10d	10"	Clear Span (Luz)+24"	18-10d
CS18-R				10"	Clear Span (Luz)+24"	18-10d
CS20	9"	Clear Span (Luz)+18"	14-8d	9"	Clear Span (Luz)+18"	16-8d
CS20-R	6"	Clear Span (Luz)+16"	12-10d	8"	Clear Span (Luz)+16"	14-10d
CS22	6"	Clear Span (Luz)+16"	14-8d	8"	Clear Span (Luz)+20"	14-8d
CS22-R	5"	Clear Span (Luz)+14"	12-10d	7"	Clear Span (Luz)+18"	12-10d
CMST14	26"	Clear Span (Luz)+52"	56-16d	30"	Clear Span (Luz)+66"	66-16d
	30"	Clear Span (Luz)+60"	66-10d	34"	Clear Span (Luz)+76"	76-10d

**NOTE:** Install half of the total fasteners in each end of strap.

Clear Span = Luz

**NOTA:** Instale la mitad de la cantidad total de sujetadores en cada extremo del fleje.

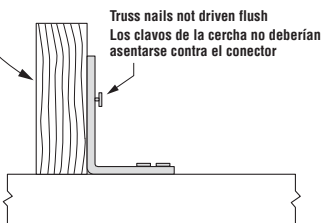
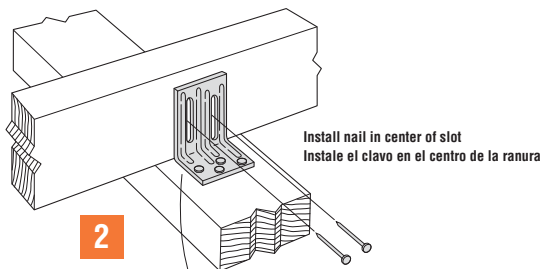
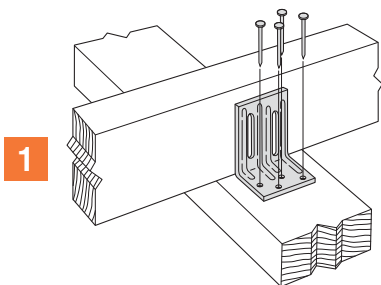

**8d**  
**(0.131" x 2½")**

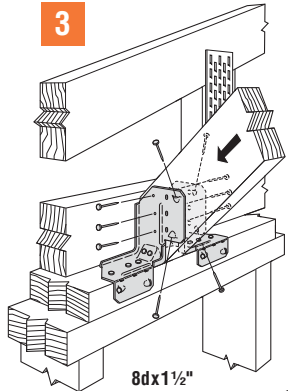
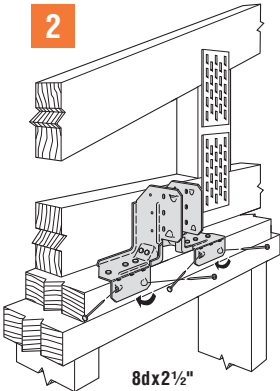
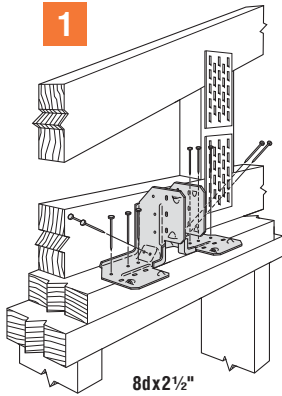
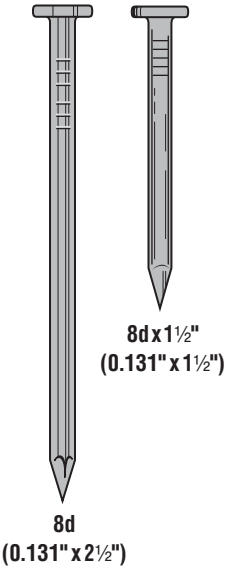

# H1 – Rafter/Cabrio

SIMPSON

Strong-Tie

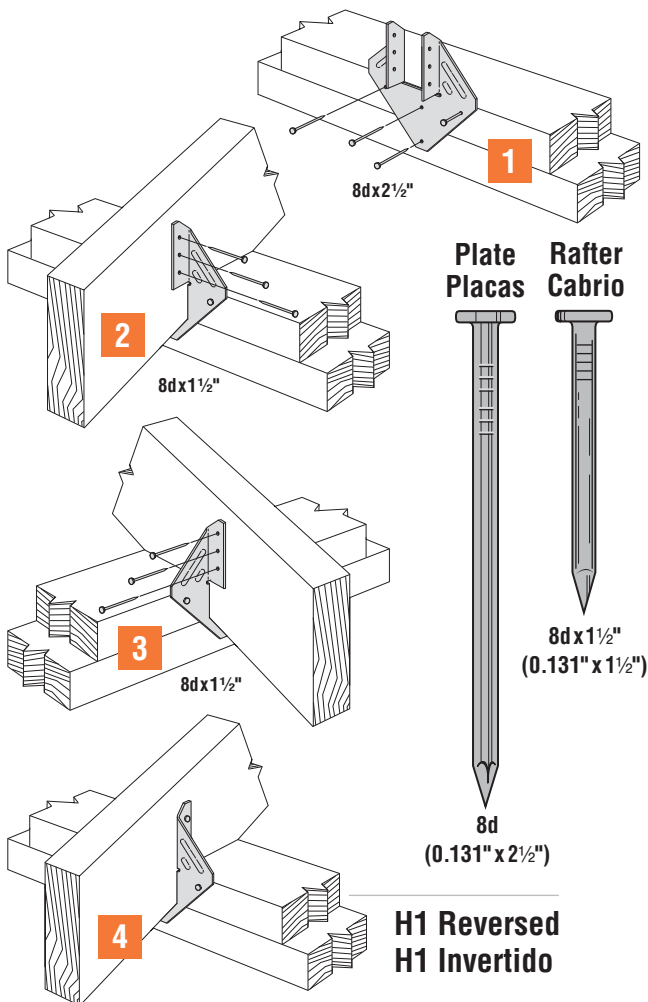



# H1 – Truss/Viga

**SIMPSON**  
**Strong-Tie**

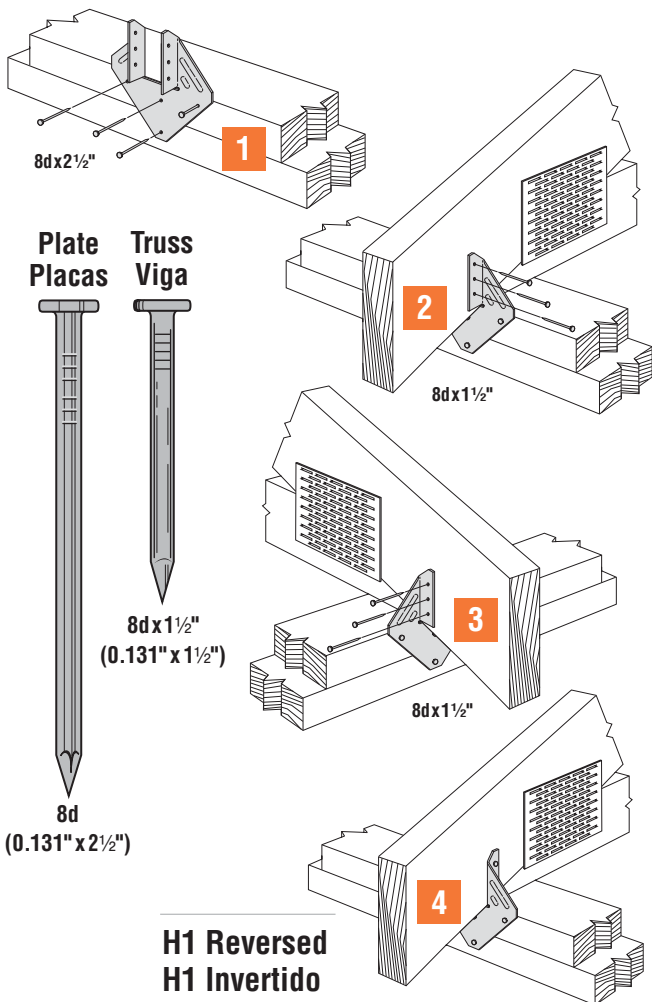

# H2.5A

SIMPSON

Strong-Tie

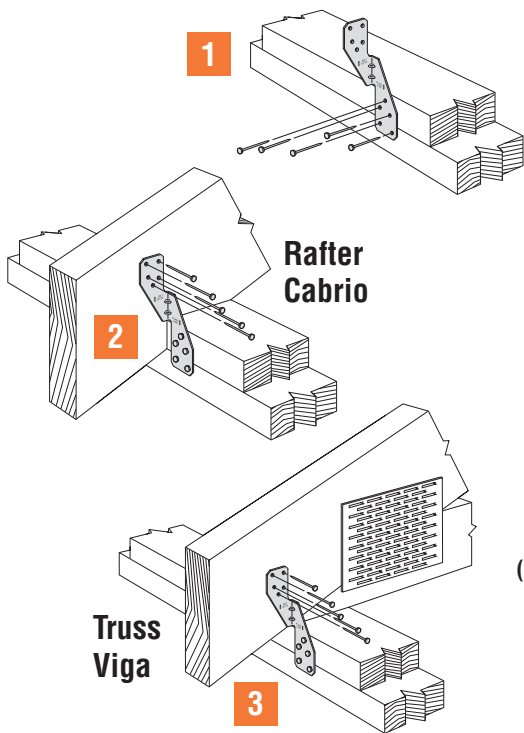

## Installations in Pairs

Both connectors shall be same model.

## Instalaciones en Pares

Ambos conectores deben ser del mismo modelo.

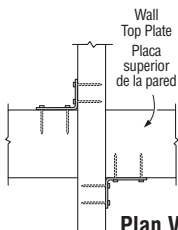

Install diagonally across from each other for minimum 2x truss.

Instale diagonalmente uno respecto del otro para dejar una cercha de 2x como mínimo.

Plan View/Vista de Planta

# H2.5T

**SIMPSON**  
**Strong-Tie**

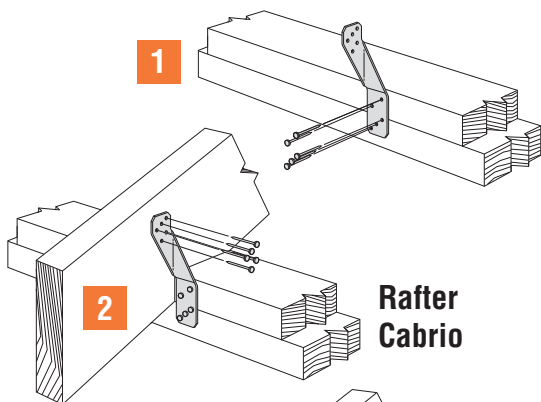

**Rafter  
Cabrio**

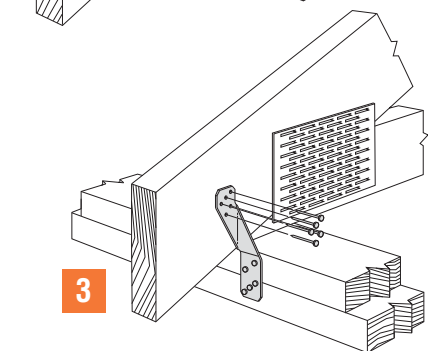

**Truss  
Vega**

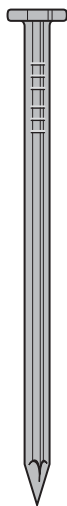

**8d**  
**(0.131" x 2½")**

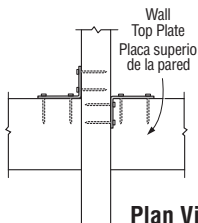

**Plan View/Vista de Planta**

Products can be on the same side of the wall provided they are configured as shown.

Los productos se pueden instalar a ambos lados de la pared siempre que se configuren como se muestra.

# H10 – Rafter/Cabrio

**SIMPSON**  
**Strong-Tie**

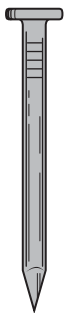

**8d x 1½"**  
**(0.131" x 1½")**

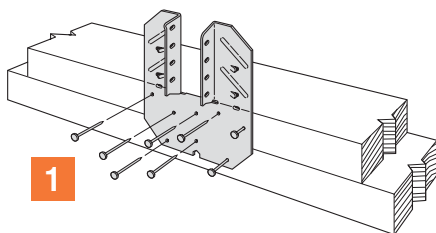

**1**

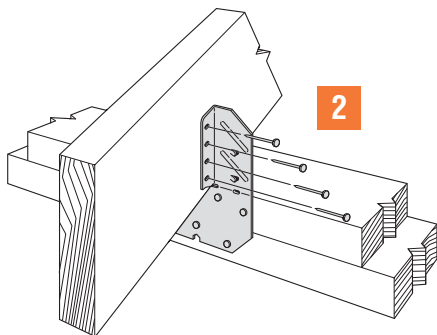

**2**

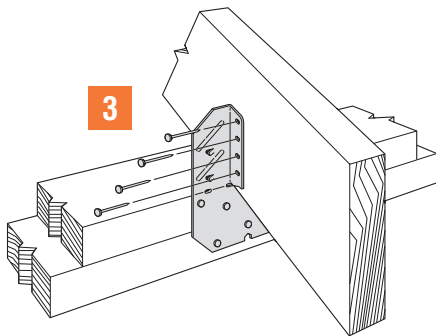

**3**

# H10 – Blocking/Entramado

**SIMPSON**  
**Strong-Tie**

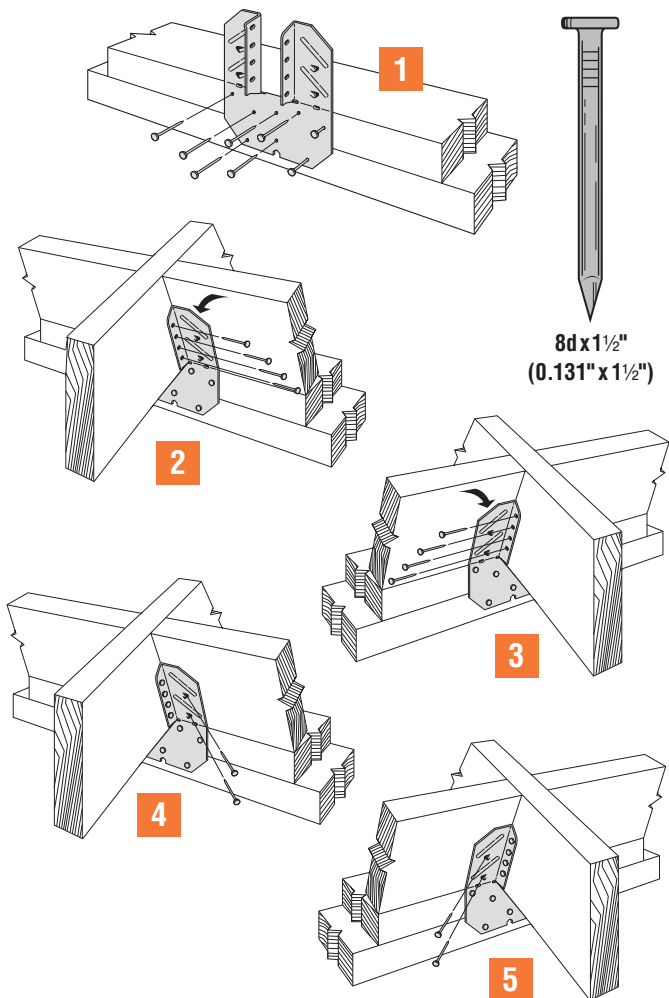

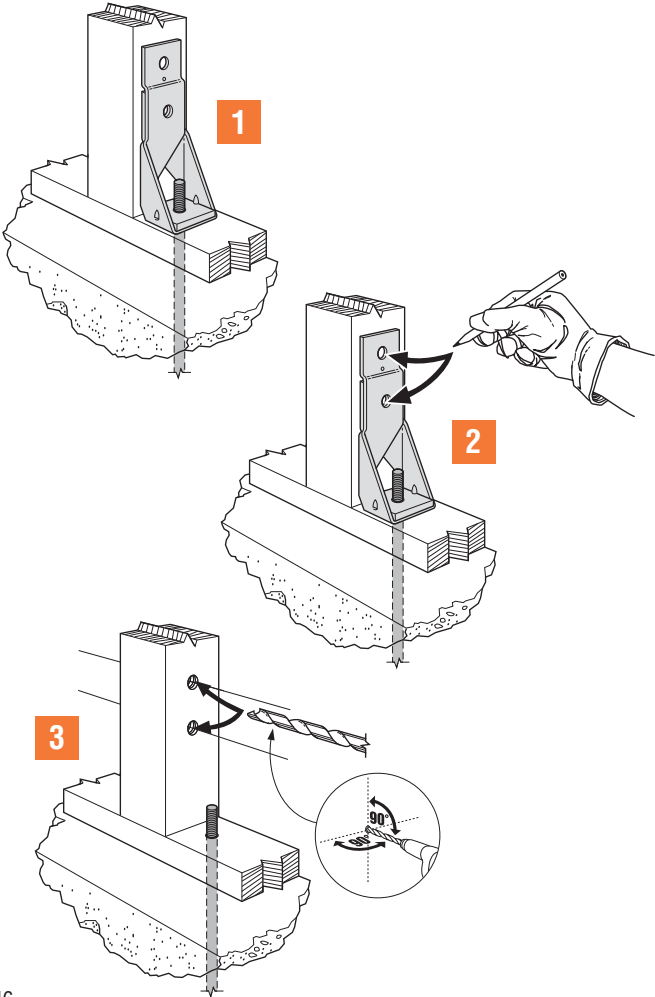

# HDA – Machine Bolts/Pernos $\frac{5}{8}$ -1"

**SIMPSON**  
Strong-Tie

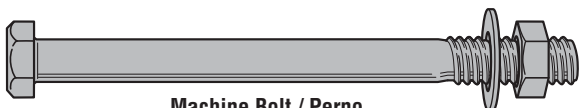
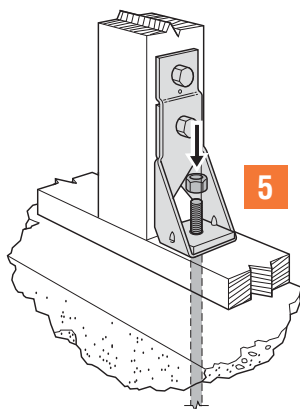
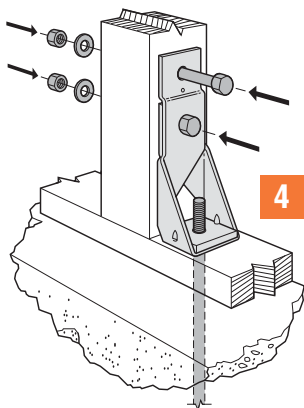

**Machine Bolt / Perno**

Model No./ N.º de Modelo	Machine Bolt Diameter/ Diámetro del Perno Torneado
HD2A	$\frac{5}{8}$ "
HD5A	$\frac{3}{4}$ "
HD6A	$\frac{7}{8}$ "
HD8A	$\frac{7}{8}$ "
HD10A	$\frac{7}{8}$ "
HD14A	1"

Machine bolts should be at least 1" longer than wood member thickness. Bolt holes must be a minimum of  $\frac{1}{32}$ " and a maximum of  $\frac{1}{16}$ " larger than bolt diameter.

Los pernos torneados deben ser al menos 1" más largos que el espesor de los miembros de madera.

Los orificios para los pernos deben ser al menos  $\frac{1}{32}$ " y como máximo  $\frac{1}{16}$ " más grandes que el diámetro del perno.

# HDQ8

**SIMPSON**  
**Strong-Tie**

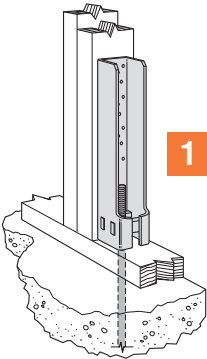

1

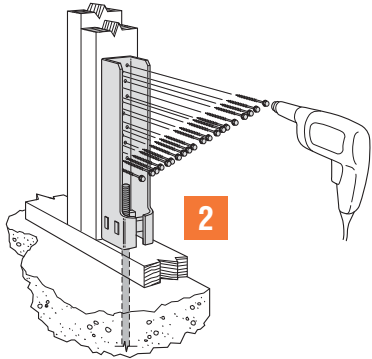

2

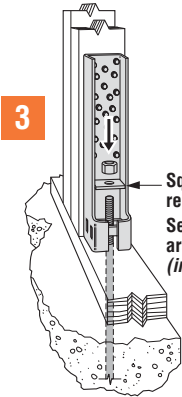

3

Square washer  
required (*included*)  
Se requiere una  
arandela cuadrada  
(*incluida*)

Use  $\frac{3}{8}$ "  
driver

Use un  
destornillador  
de  $\frac{3}{8}$ "

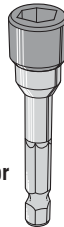

**SDS  $\frac{1}{4}$ " x 3"**  
(*Included / Incluida*)



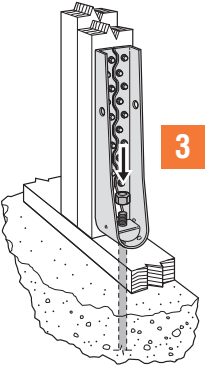
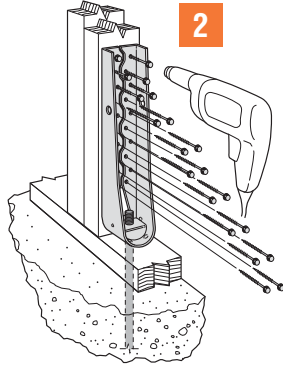
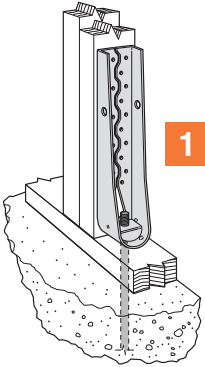

Use  $\frac{3}{8}$ "  
driver

Use un  
destornillador  
de  $\frac{3}{8}$ "

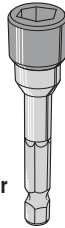

**SDS  $\frac{1}{4}$ " x  $2\frac{1}{2}$ "**  
**(Included / Incluida)**

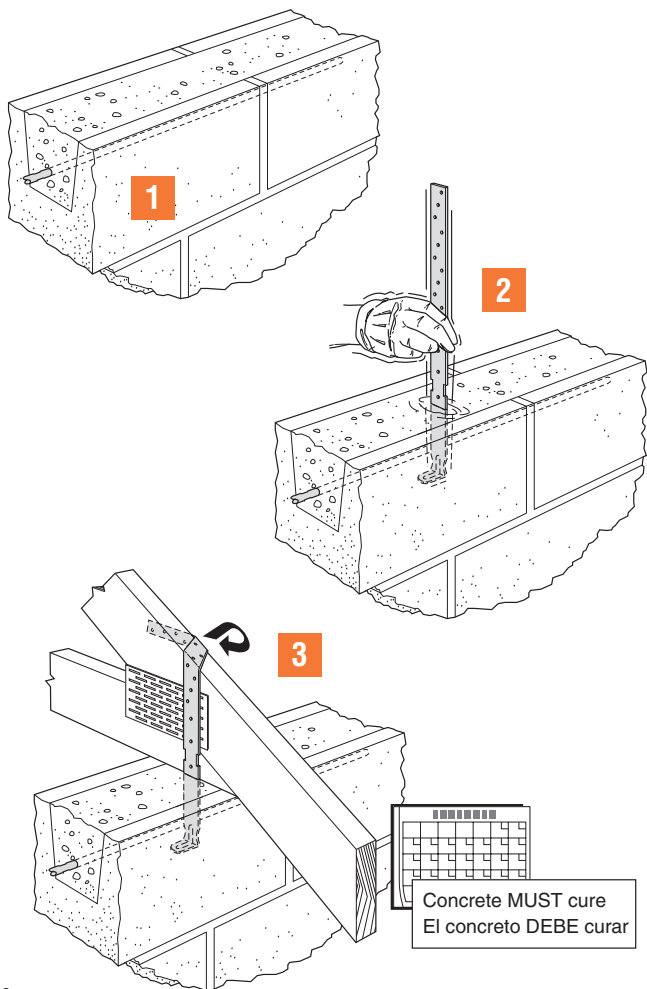

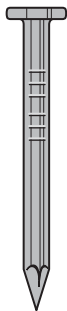

**10d x 1½"**  
**(0.131" x 1½")**

**Quantity per  
Designer**

**Cantidad según  
indicaciones del  
diseñador**

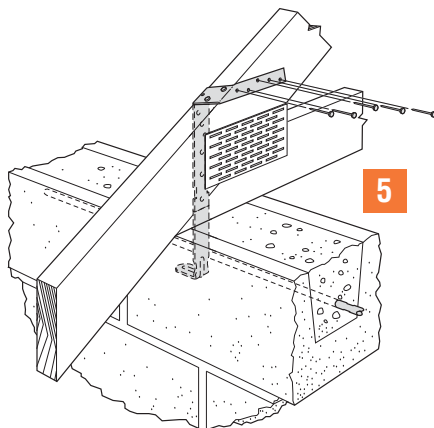
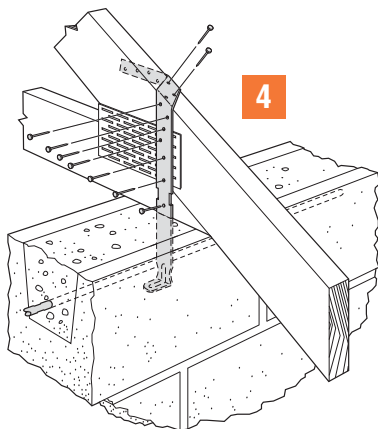

**1a**

**Nailed to block on form**  
**Clavado al bloque en forma**

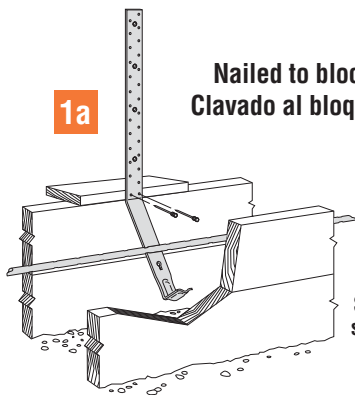

**or/ó**

**StrapMate®**  
**strap holder**  
**(SM1)**

**1b**

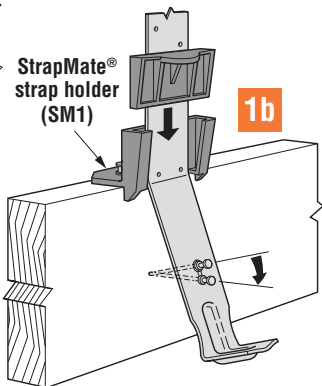

**2**

**Attached with StrapMate®**  
**strap holder**

**Fijar con sujetador de abraza-**  
**dera StrapMate®**

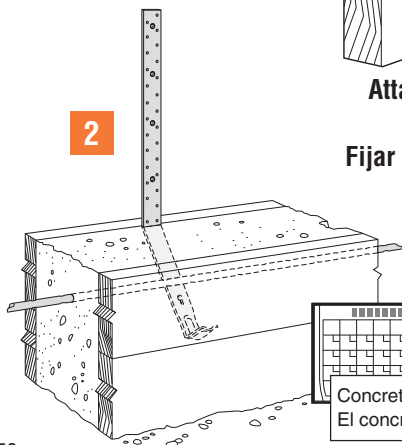

**Concrete MUST cure**  
**El concreto DEBE curar**

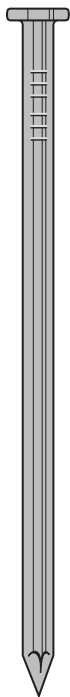

**16d**  
**(0.162" x 3 1/2")**

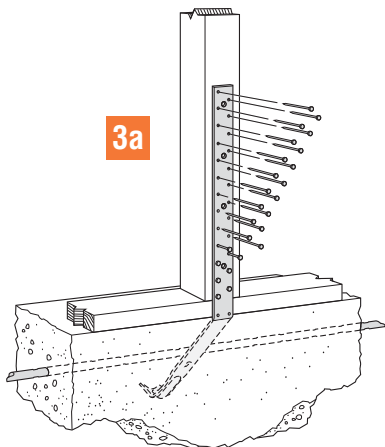

**Strap may be bent down  
and back up one time only**

**La abrazadera se puede  
doblar hacia abajo y hacia  
arriba sólo una vez**

**or/ó**

**Reduced loads apply.  
Check with Designer  
before nailing over  
sheathing**

**Se aplican cargas  
reducidas. Consulte  
al diseñador antes de  
clavar sobre  
relleno**

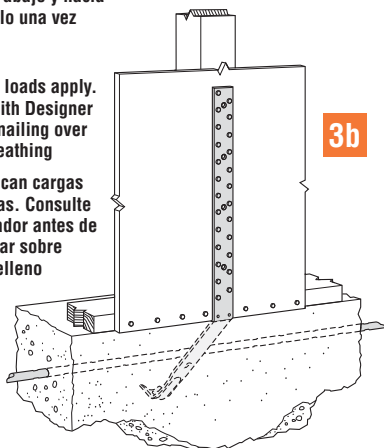

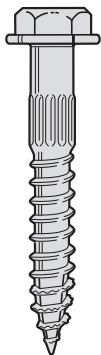

**SDS 1/4" x 1 1/2"**

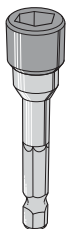
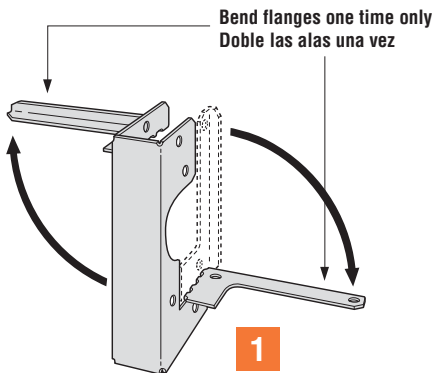

**Use 3/8" driver**  
**Use un destornillador de 3/8"**

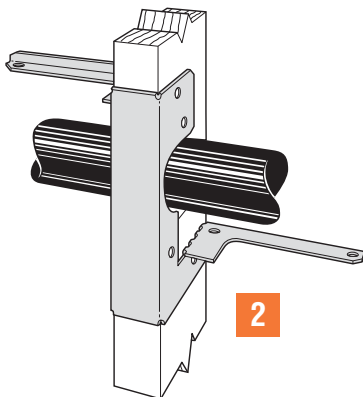

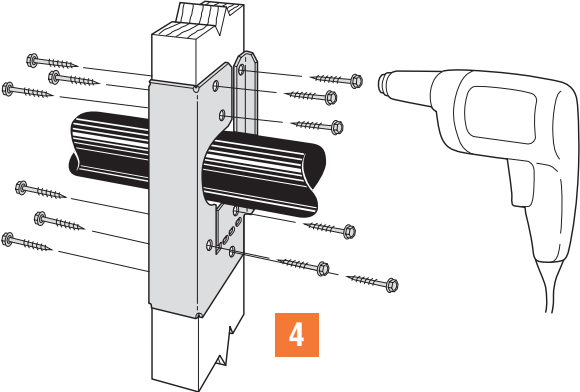
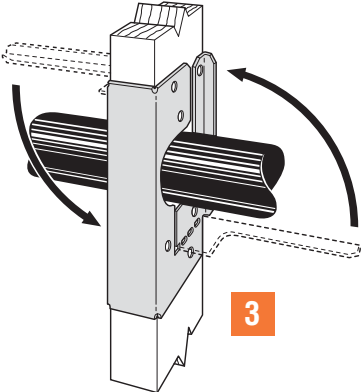

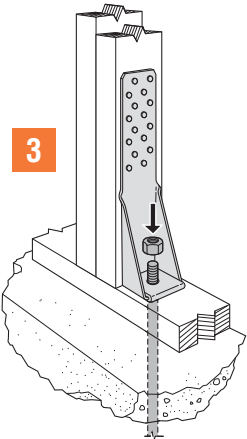
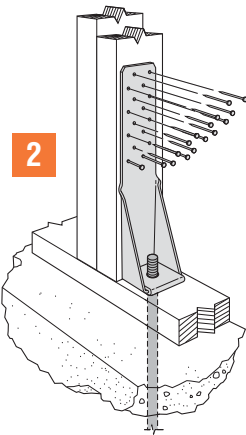
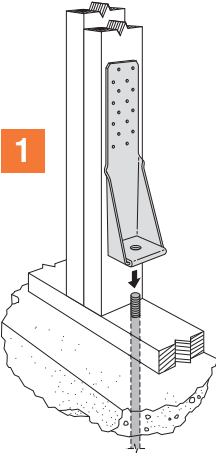

HTT4  
HTT5  
HTT16    HTT22

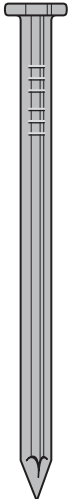

**16d x 2 1/2"**  
**(0.162" x 2 1/2")**

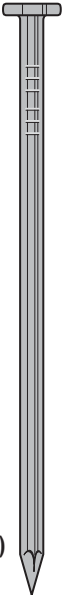

**10d**  
**(0.148" x 3")**



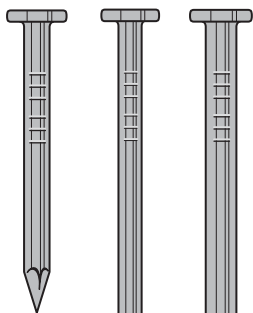
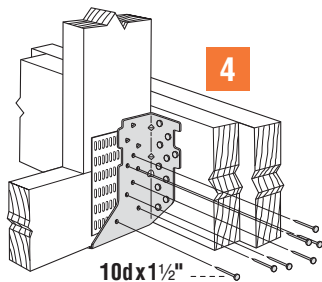
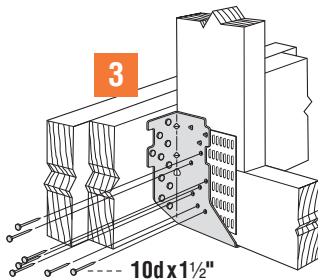
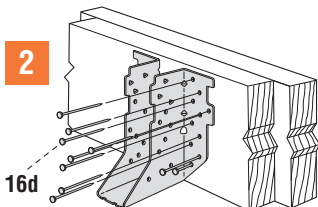
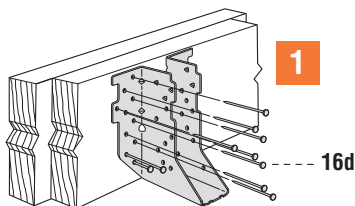

16d  
10d x 1/2"  
(0.148" x 1/2")

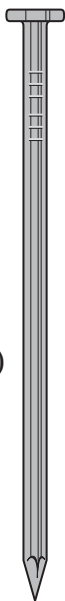

10d  
(0.148" x 3")  
For double  
2x joists

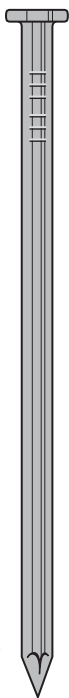

16d  
(0.162" x 3 1/2")

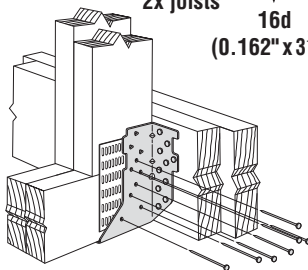

For double truss use 10d x 3" nails into trusses  
Para cerchas dobles, use clavos  
10d x 3" insertados en las cerchas

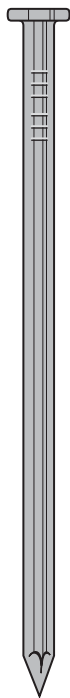
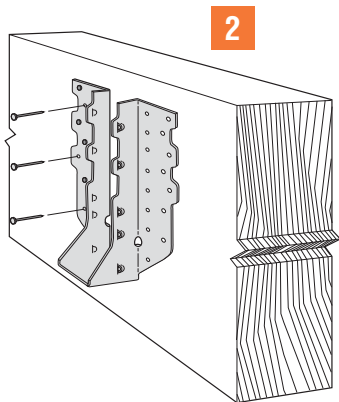
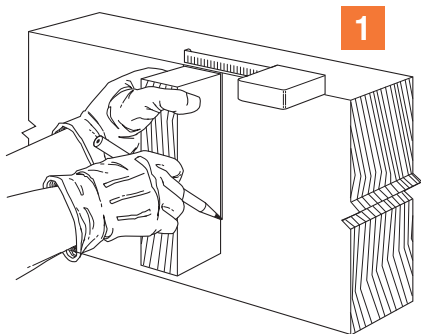

**16d**  
**(0.162" x 3 1/2")**

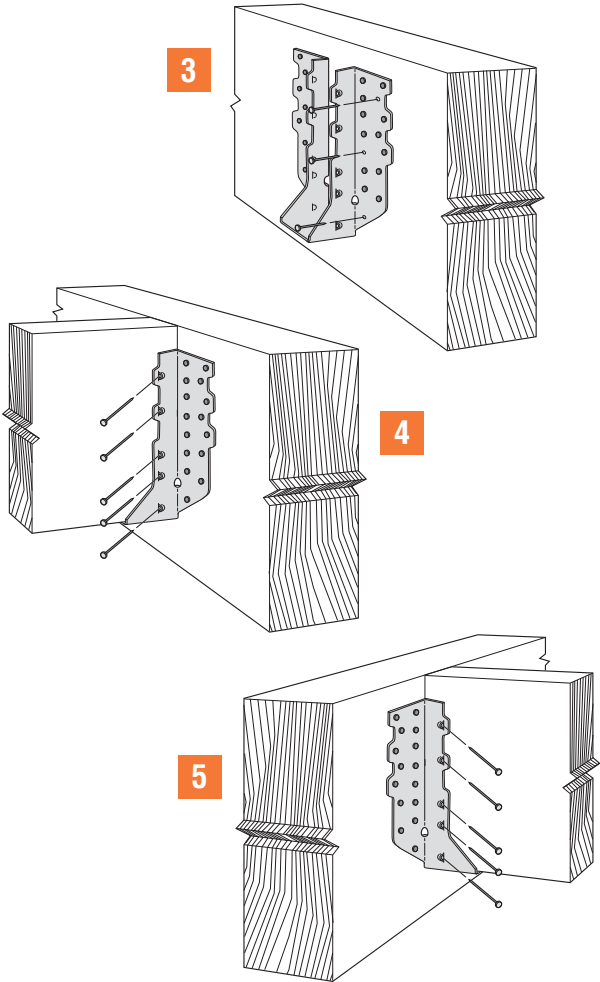

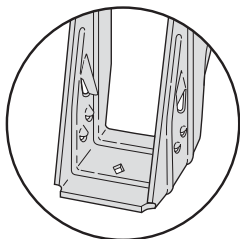

The Strong-Grip™ seat allows the I-joist to “snap” in securely – no joist nails needed.

El asiento Strong-Grip™ permite que la viga ‘I’ “encaje” con firmeza; no se necesitan clavos para vigas.

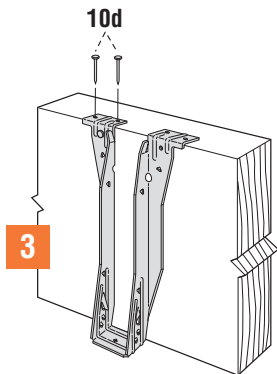
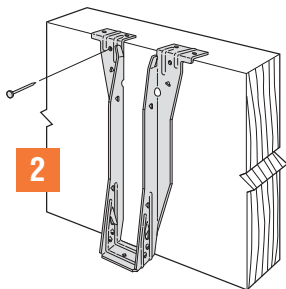
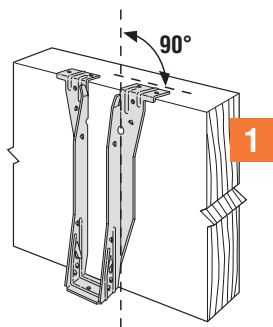

See pages 14-15 for more information.

Vea la página 14-15 para más información.



**10d**  
(0.148" x 3")

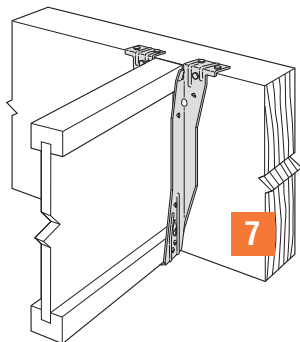
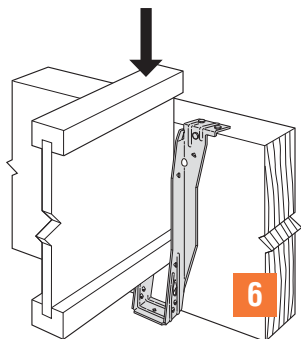
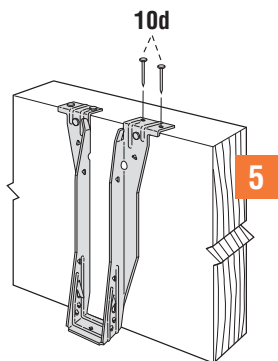
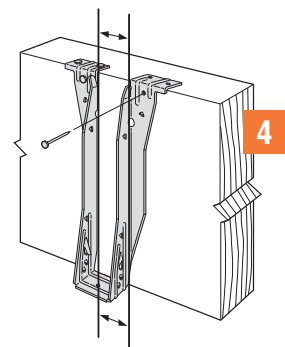

**No nails required in joist**  
**No es necesario clavar**  
**clavos en la viga**

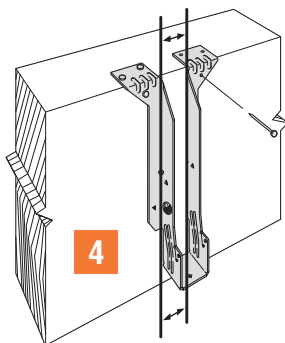
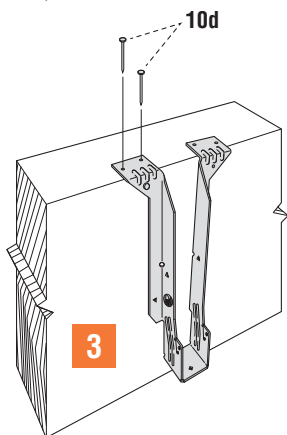
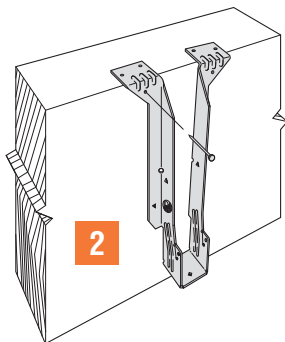
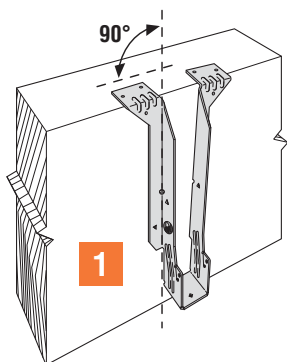

See pages 14-15 for more information.  
Vea la página 14-15 para más información.



**10d (0.148" x 3")**  
On top and face by header  
Encima y en la cara de la viga cabezal

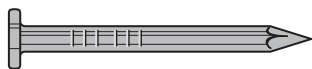
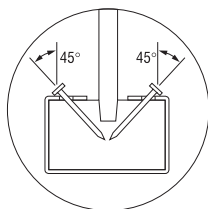
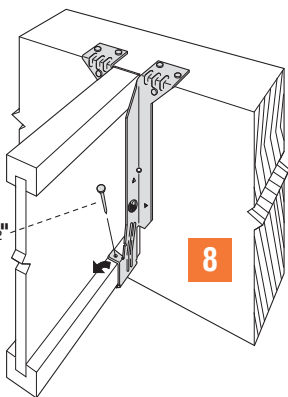
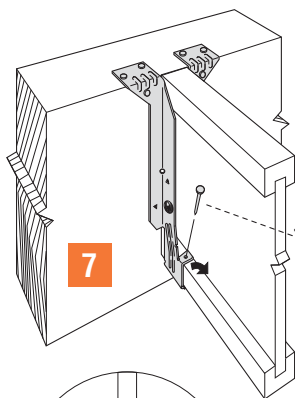
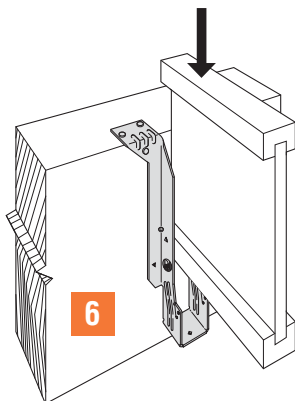
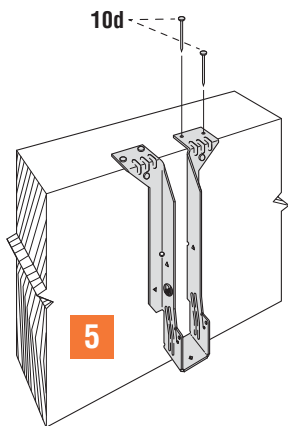

**10dx1/2" (0.148" x 1/2")**  
At joist  
En la vigueta

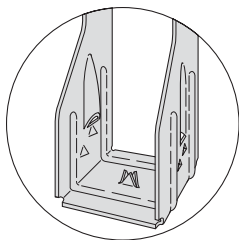

The Strong-Grip™ seat allows the I-joist to “snap” in securely – no joist nails needed.

El asiento Strong-Grip™ permite que la viga en ‘I’ “encaje” con firmeza; no se necesitan clavos para vigas.

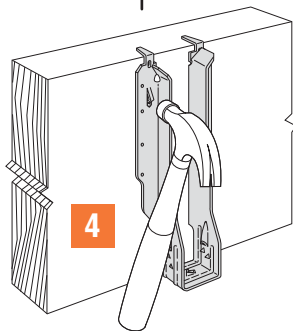
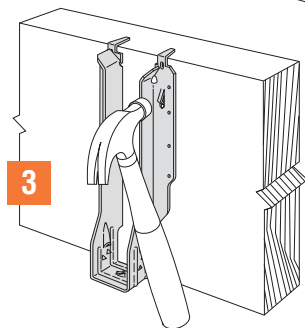
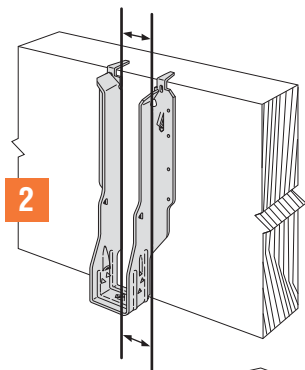
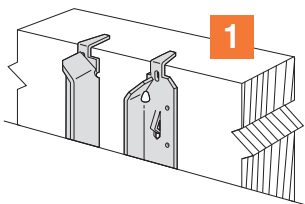

See pages 14-15 for more information.  
Vea la página 14-15 para más información.

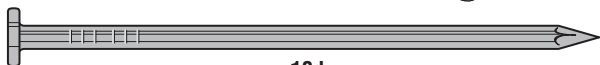

**10d**  
**(0.148" x 3")**



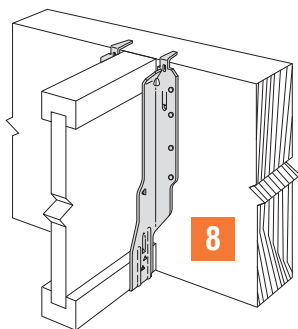
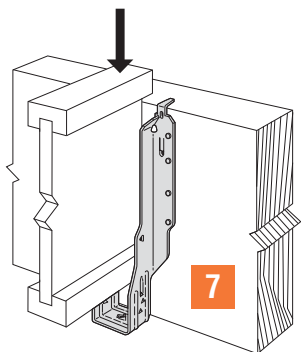
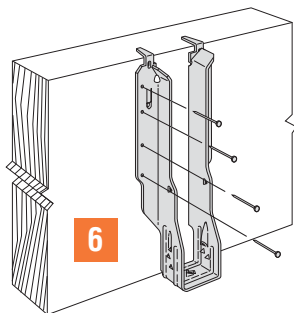
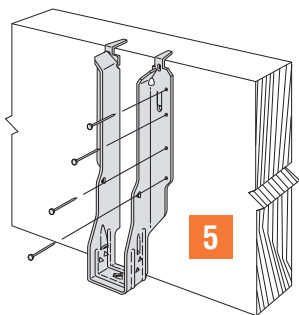

**No nails required in joist**  
**No es necesario clavar**  
**clavos en la viga**

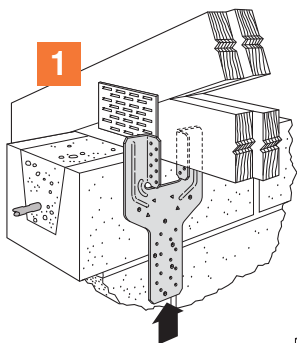

**1**

Fill  holes with  
Titen® masonry screws

Llene los orificios   
con tornillos para  
mampostería Titen®

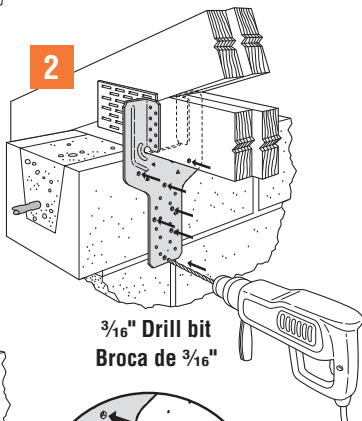

**2**

$\frac{3}{16}$ " Drill bit  
Broca de  $\frac{3}{16}$ "

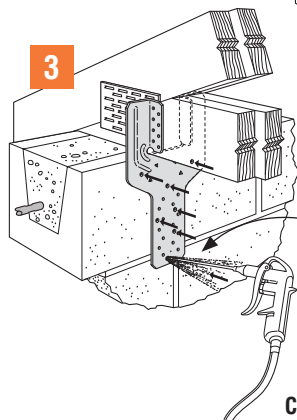

**3**

Compressed Air / Aire comprimido



**Titen® Masonry Screw/Tornillo para mampostería ( $\frac{1}{4}$ " x  $2\frac{1}{4}$ " )**

**For installation in concrete use Titen  $\frac{1}{4}$ " x  $1\frac{3}{4}$ "**

**Para instalaciones en concreto, utilice Titen de  $\frac{1}{4}$ " x  $1\frac{3}{4}$ "**

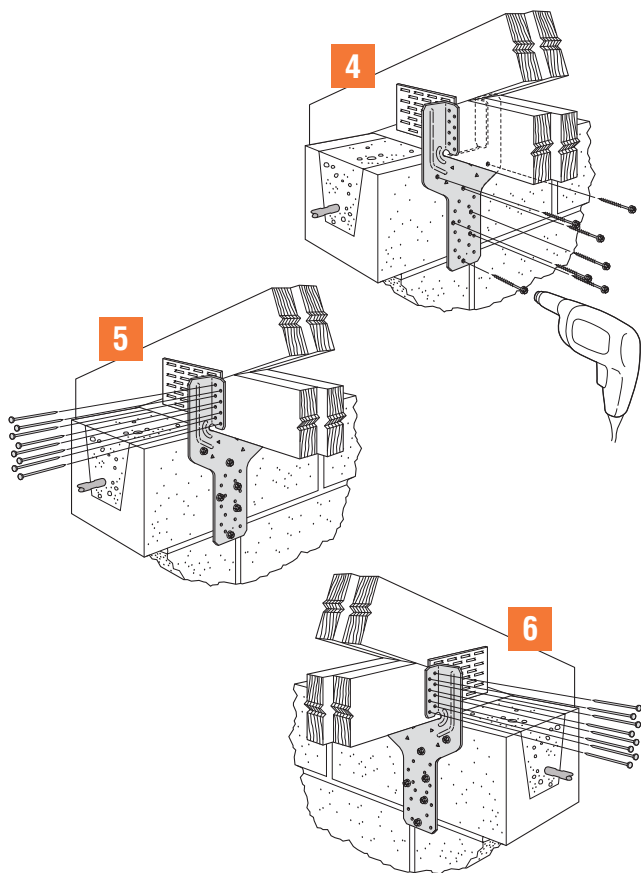

**16d Sinker**  
(0.148" x 3/4")

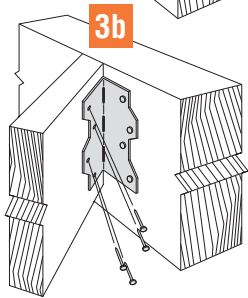
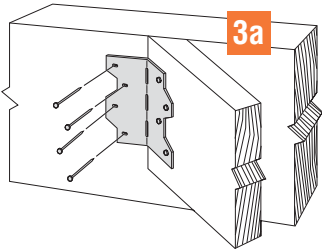
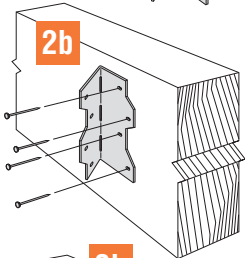
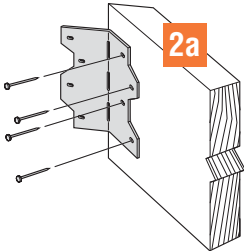
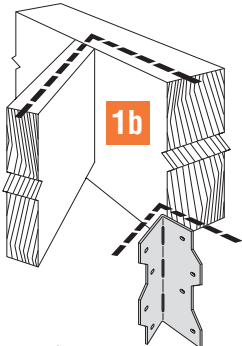
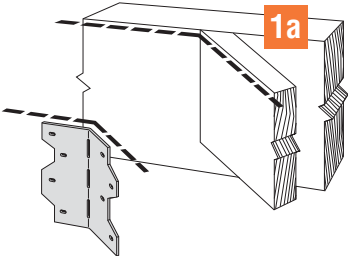

**10d**  
**(0.148" x 3")**

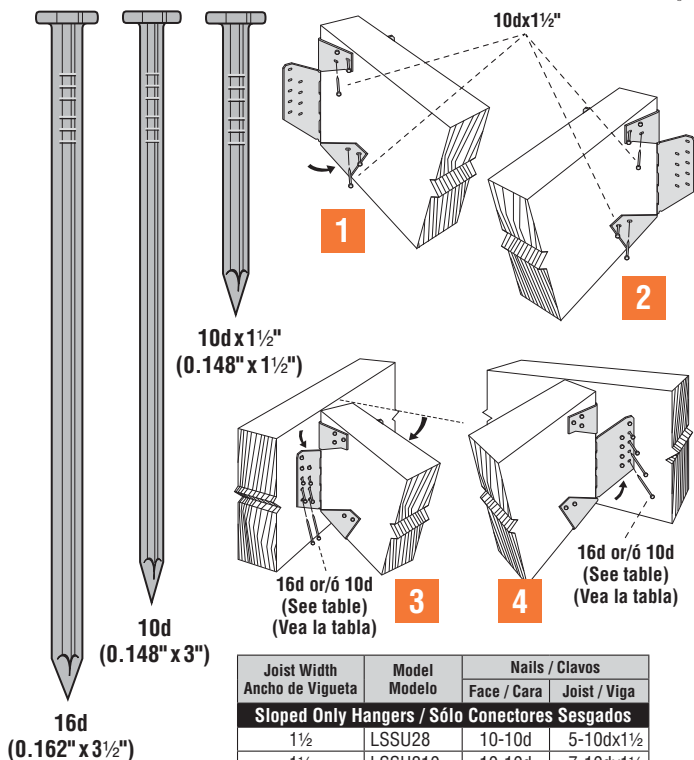

Joist Width Ancho de Vigueta	Model Modelo	Nails / Clavos	
		Face / Cara	Joist / Viga
<b>Sloped Only Hangers / Sólo Conectores Sesgados</b>			
1 1/2	LSSU28	10-10d	5-10dx1 1/2
1 1/2	LSSU210	10-10d	7-10dx1 1/2
2 1/2	LSSUH310	18-16d	12-10dx1 1/2
3	LSSU210-2	18-16d	12-10dx1 1/2
3 1/2	LSSU410	18-16d	12-10dx1 1/2
<b>Skewed Hangers or Sloped and Skewed Conectores Sesgados o Con Seño y Pendiente</b>			
1 1/2	LSSU28	9-10d	5-10dx1 1/2
1 1/2	LSSU210	9-10d	7-10dx1 1/2
2 1/2	LSSUH310	14-16d	12-10dx1 1/2
3	LSSU210-2	14-16d	12-10dx1 1/2
3 1/2	LSSU410	14-16d	12-10dx1 1/2

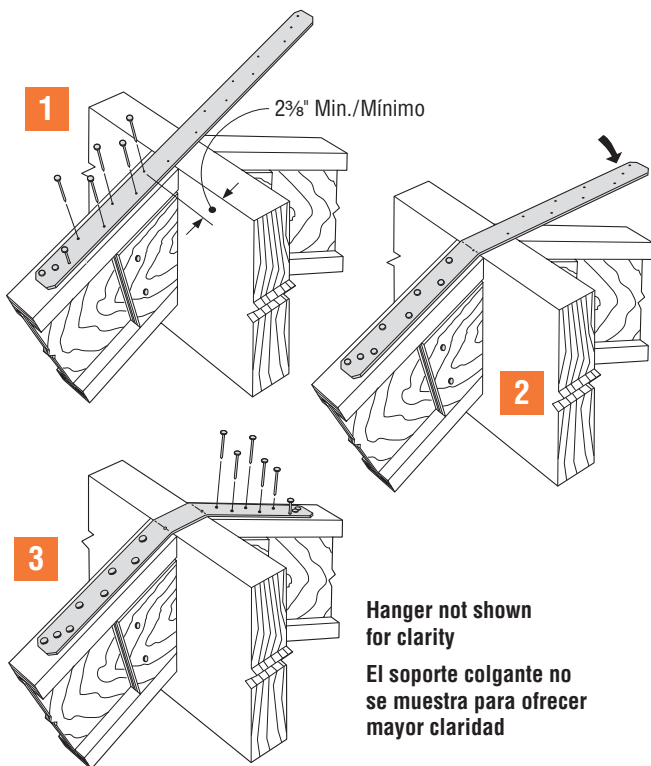

**10d (0.148" x 3")**



**10d x 1/2" (0.148" x 1/2")**

**For I-joist installation only**

**Sólo para instalación de vigas en 'I'**

# LTHJR

**SIMPSON**  
**Strong-Tie**

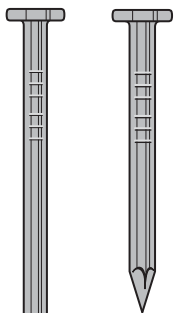

**10d x 1½"**  
**(0.148" x 1½")**

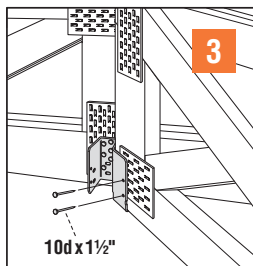
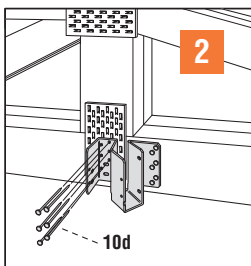
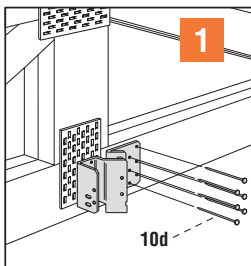

**10d**  
**(0.148" x 3")**

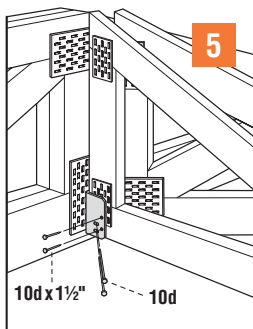
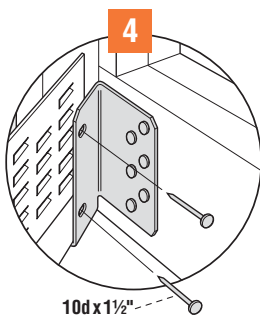

# LTP4/LTP5

**SIMPSON**  
**Strong-Tie**

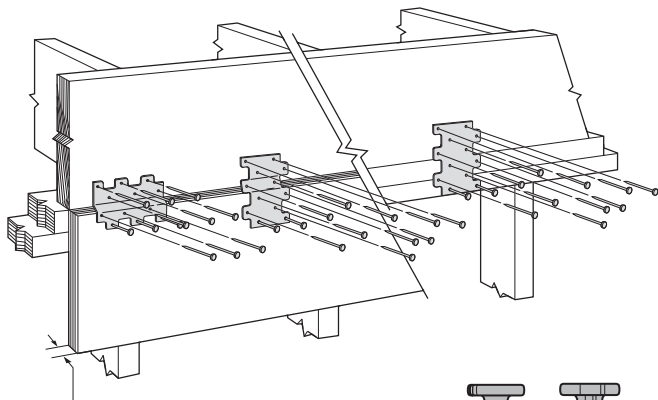

## Fasteners:

### LTP4

No sheathing: 8d x 1 1/2"

Over sheathing (3/8" thick max.): 8d x 2 1/2"

### LTP5

No sheathing: 8d x 1 1/2"

Over sheathing (1/2" thick max.): 8d x 2 1/2"

## Sujetadores:

### LTP4

Sin relleno: 8d x 1 1/2"

Sobre relleno (3/8" de espesor máx.): 8d x 2 1/2"

### LTP5

Sin relleno: 8d x 1 1/2"

Sobre relleno (1/2" de espesor máx.): 8d x 2 1/2"

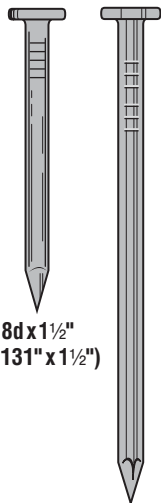

8d x 1 1/2"  
(0.131" x 1 1/2")

8d  
(0.131" x 2 1/2")



Header  
Viga cabezal

Joist  
Viga

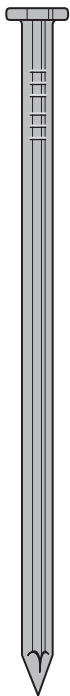

16d  
(0.162" x 3½")

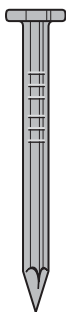

10d x 1½"  
(0.148" x 1½")

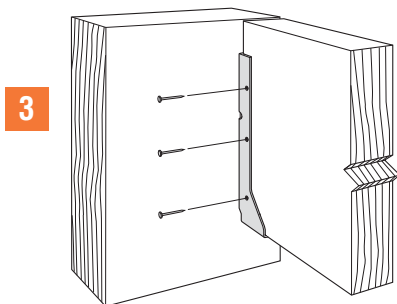
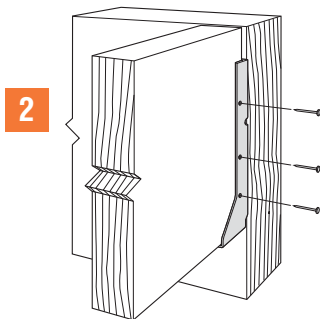
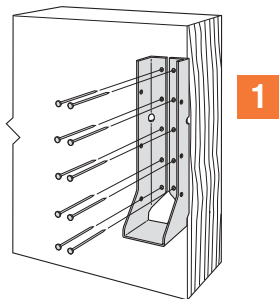

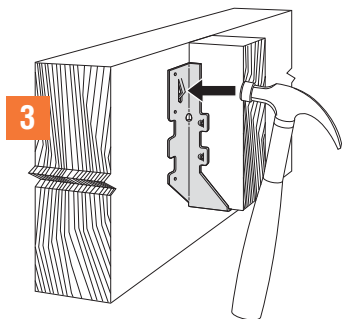
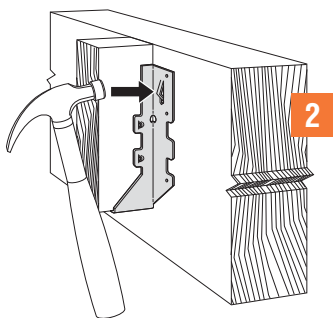
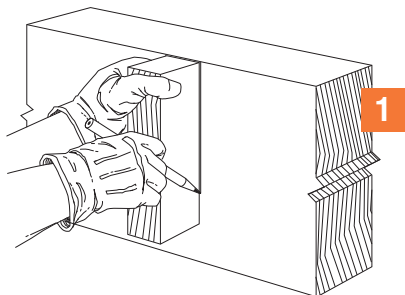

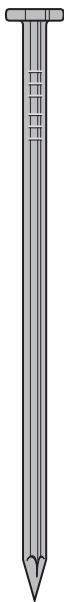
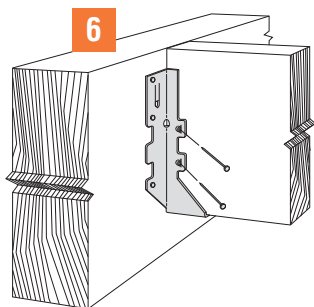
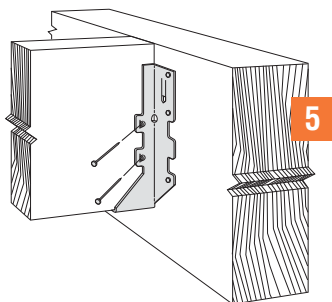
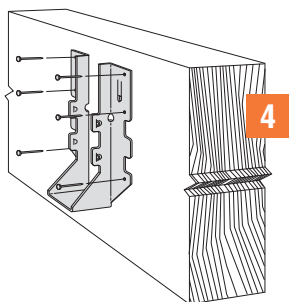

**10d for single 2x**  
**10d para un solo 2x**  
**(0.148" x 3")**

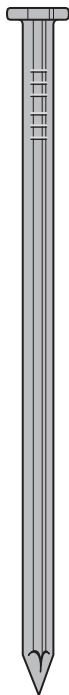

**16d for all others**  
**16d para los demás**  
**(0.162" x 3½")**

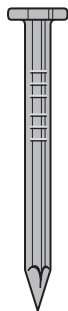
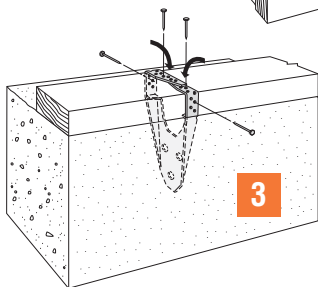
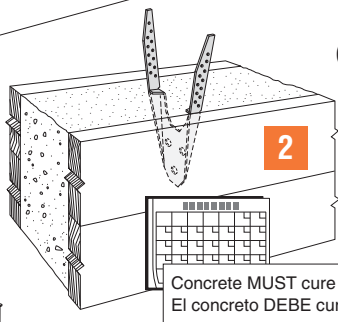
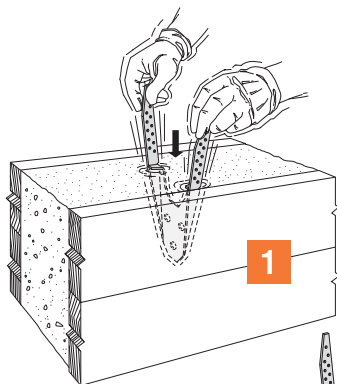

**10d x 1/2"**  
**(0.148" x 1/2")**

**Stud installation similar**  
**Similar a la instalación en montantes**

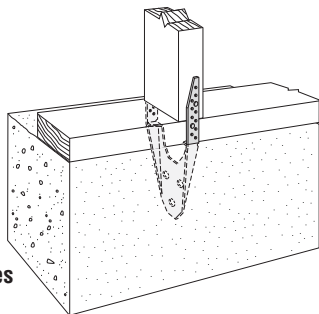

# MAB – Block/Bloque

**SIMPSON**  
**Strong-Tie**

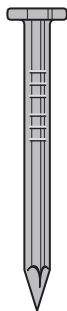
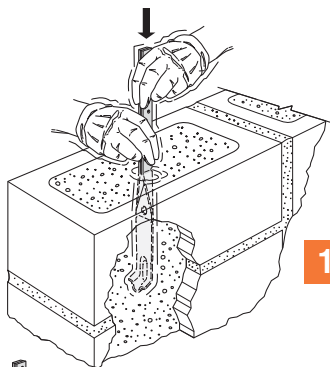

10d x 1½"  
(0.148" x 1½")

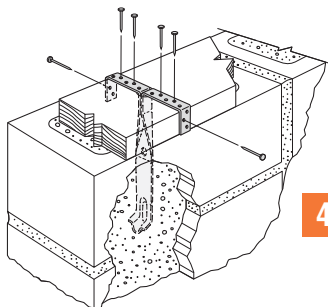
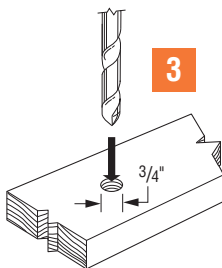
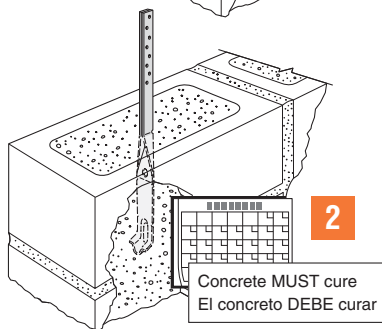

# MAB – Concrete/Concreto

**SIMPSON**  
**Strong-Tie**

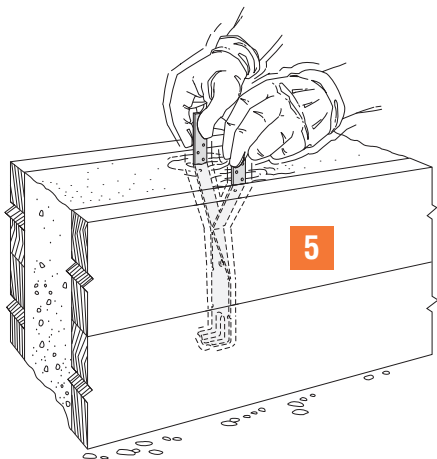
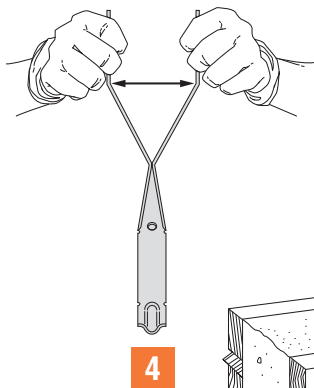
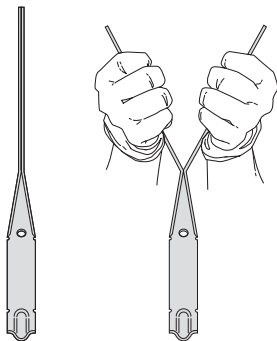
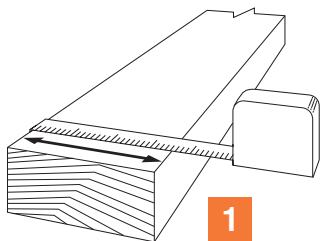

# MAB – Concrete/Concreto

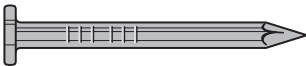
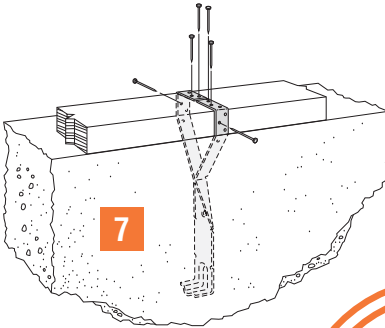
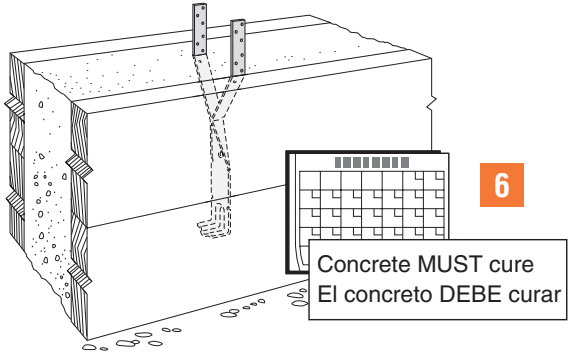

**10d x 1½"**  
**(0.148" x 1½")**

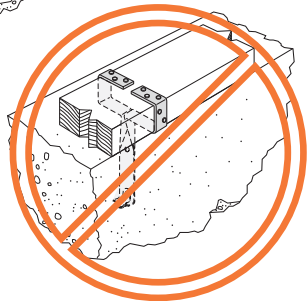

# MASA/MAS

**SIMPSON**

**Strong-Tie**

**FORMING  
ENCOFRADO**

**CONNECTOR  
CONECTOR**

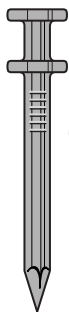

**8d  
Duplex**

or/ó

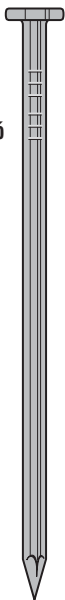

**10d  
(0.148" x 3")**

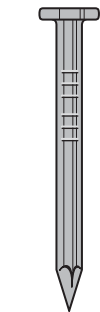

**10d x 1 1/2"  
(0.148" x 1 1/2")**

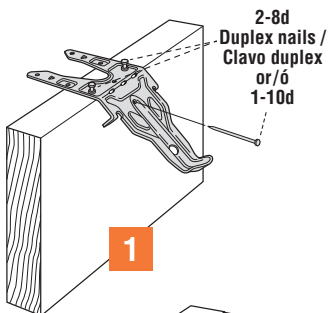

2-8d  
Duplex nails /  
Clavo duplex  
or/ó  
1-10d

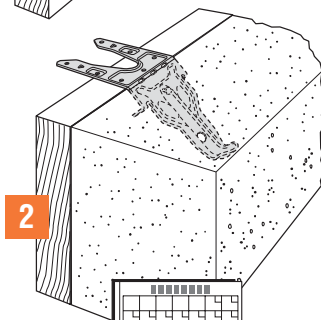

Concrete **MUST** cure  
El concreto **DEBE** curar

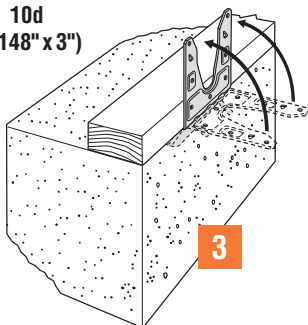



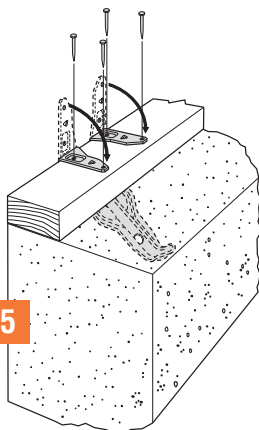
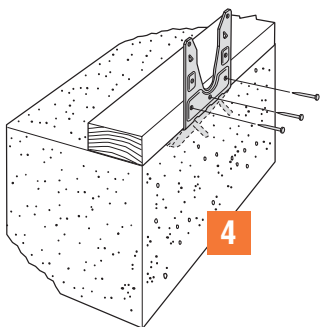

**Option 1**  
**Opción 1**

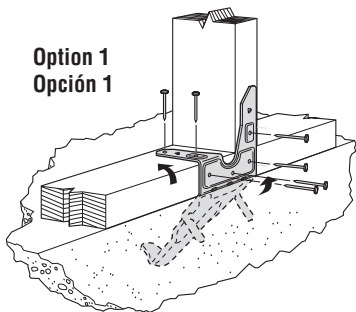

**Reduced loads apply,  
check with Designer**

**Se aplican cargas reducidas;  
consulte al diseñador**

Blocking required attached to sill with  
A35Z (not shown) or per Designer

Se debe adjuntar un bloqueo al  
larguero con A35Z (no se muestra)  
o según indicaciones del diseñador

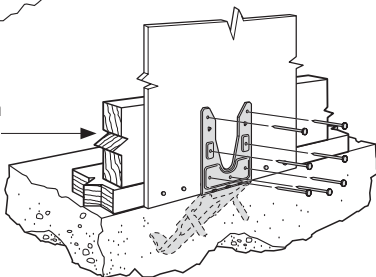

**Option 2**  
**Opción 2**

**Reduced loads apply, check with Designer  
before nailing over sheathing**

**Se aplican cargas reducidas; consulte al  
diseñador antes de clavar sobre el relleno**

## Brick-Ledge Installation Instalación Sobre Cornisa de Ladrillos

2-8d Duplex nails / Clavo duplex or/ó 1-10d

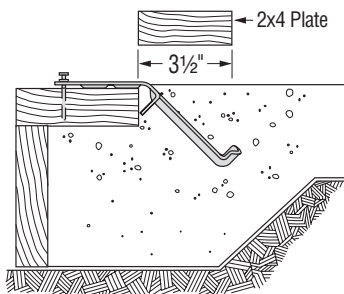
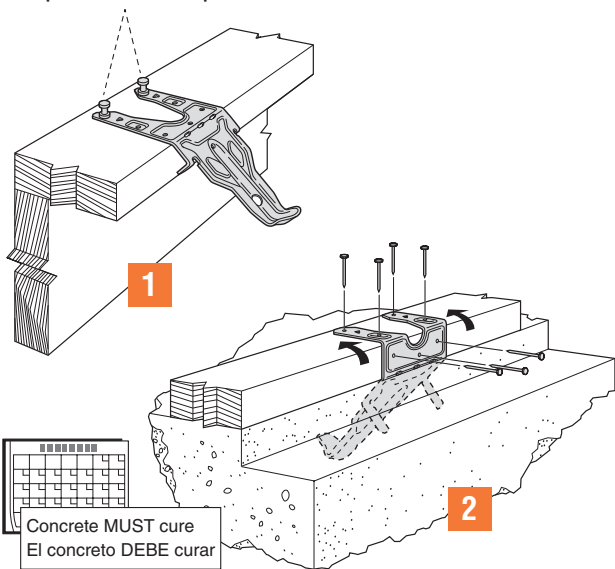

## Inside-the-Mudsill Installation Instalación en Solera

2-8d Duplex nails / Clavo duplex or/ó 1-10d

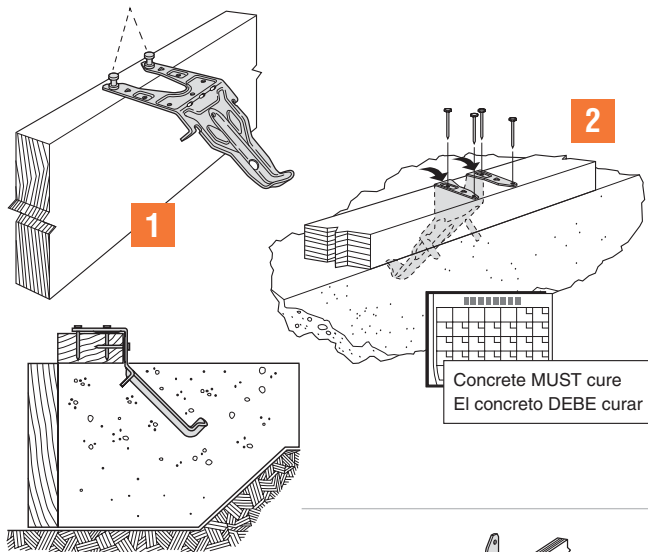

**MASAP/MASP**  
**Similar / Similar**

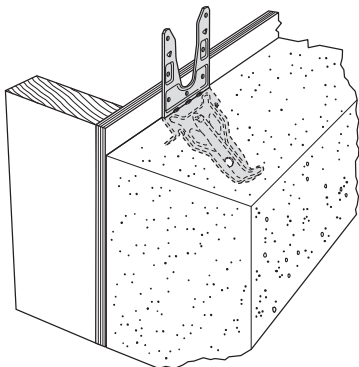

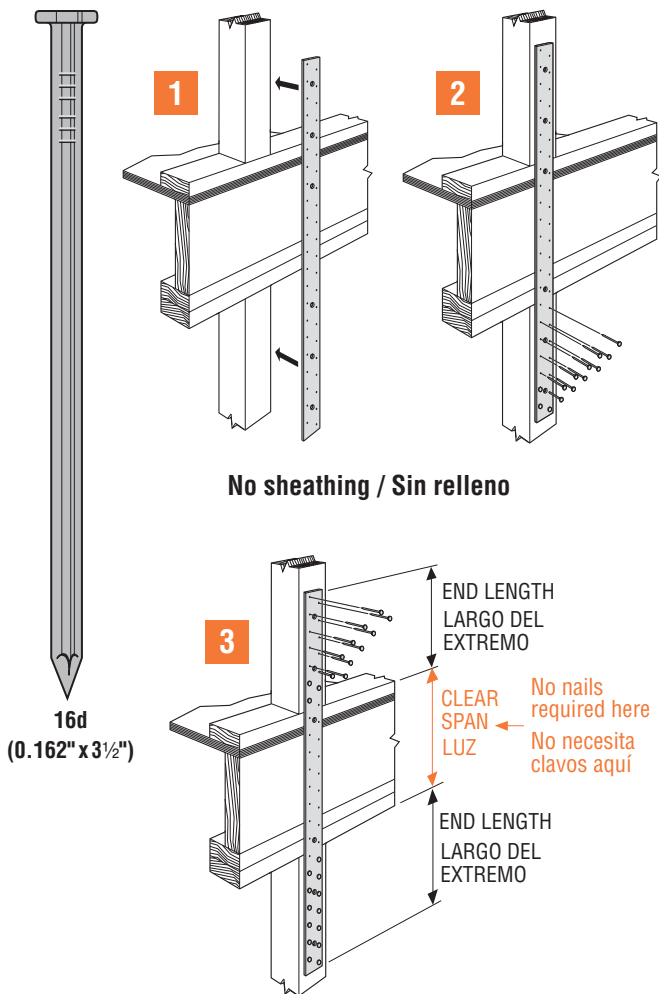

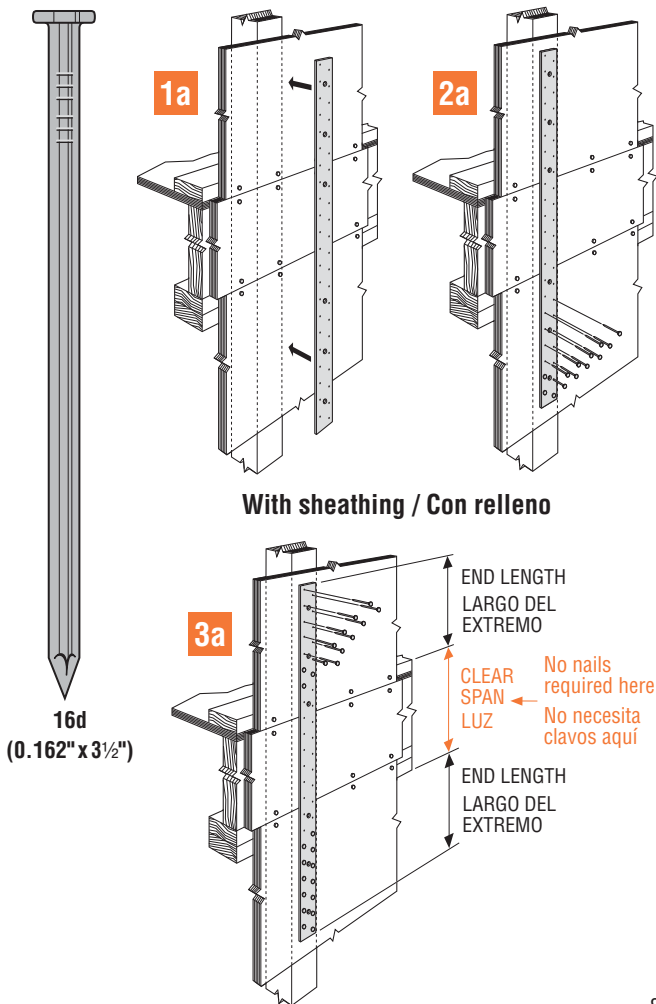

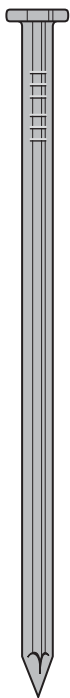

**16d**  
(0.162" x 3½")

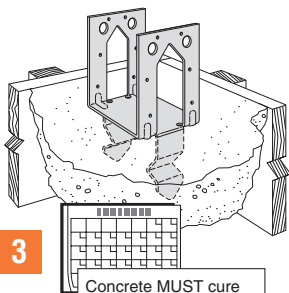
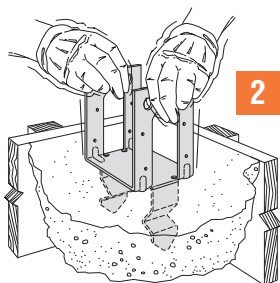
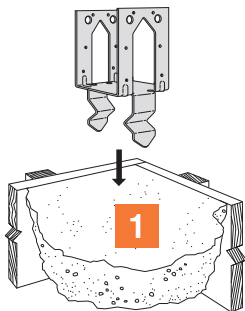

Concrete **MUST** cure  
El concreto **DEBE** curar

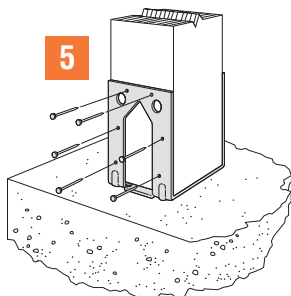
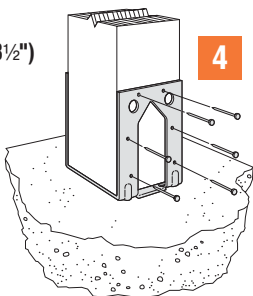

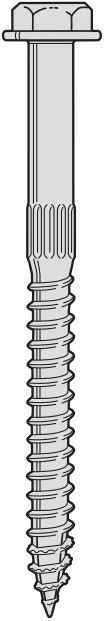

SDS 1/4" x 3"

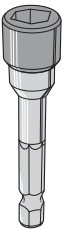

Use 3/8" driver  
Use un  
destornillador  
de 3/8"

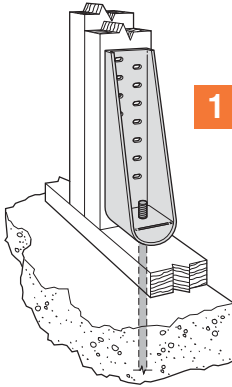

1

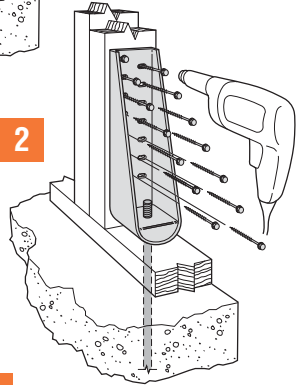

2

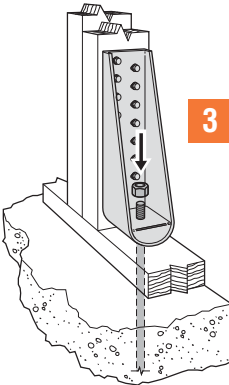

3

**Nut should be finger tight plus  
1/8 to 1/2 turn with a hand wrench  
(do not use an impact wrench)**

**La tuerca se debe ajustar a mano más  
1/8 a 1/2 de vuelta con una llave de mano  
(no usar una llave de impacto)**

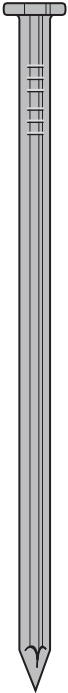

**16d**  
**(0.162" x 3 1/2")**

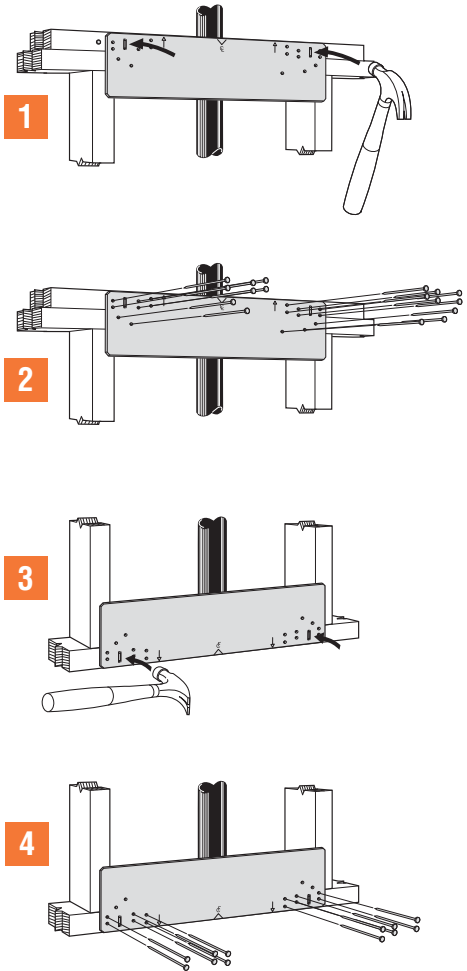



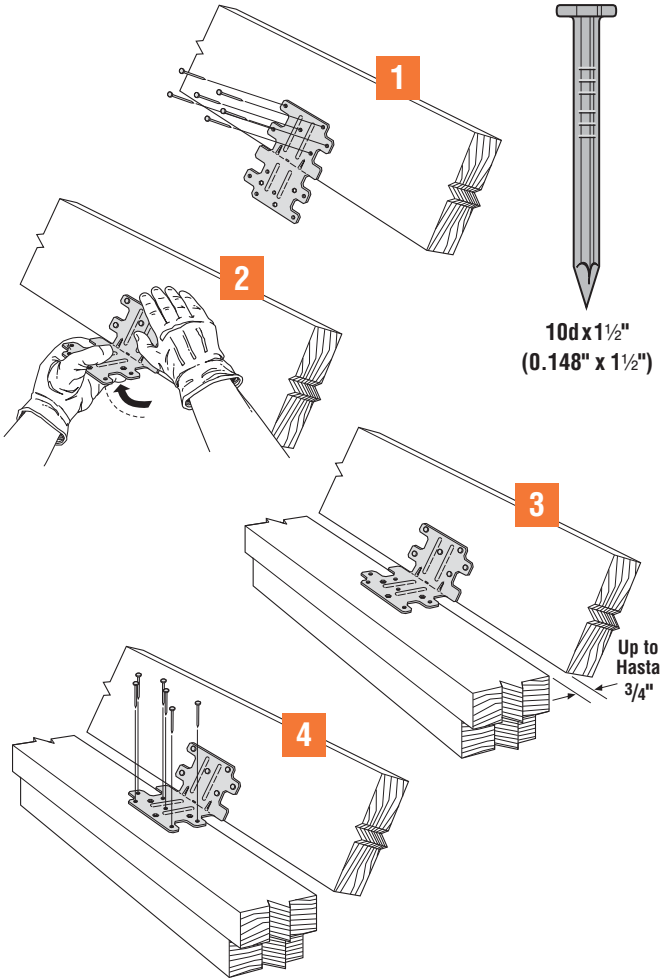

# RSP4

**SIMPSON**  
**Strong-Tie**

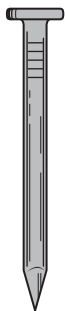

**8d x 1 1/2"**  
**(0.131" x 1 1/2")**

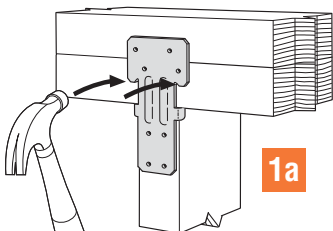

**1a**

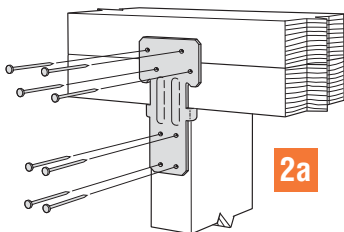

**2a**

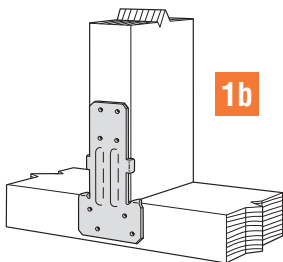

**1b**

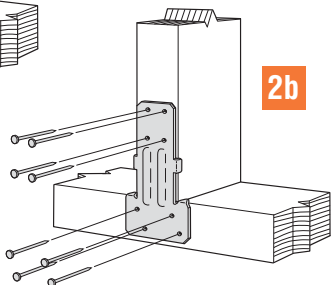

**2b**

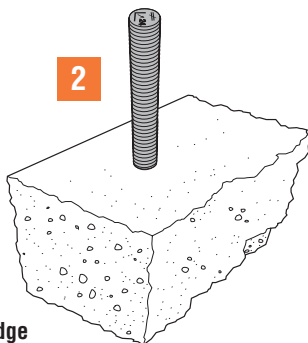
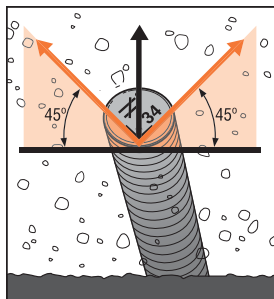
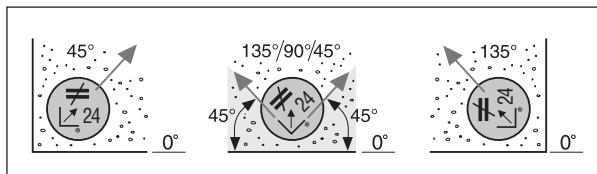
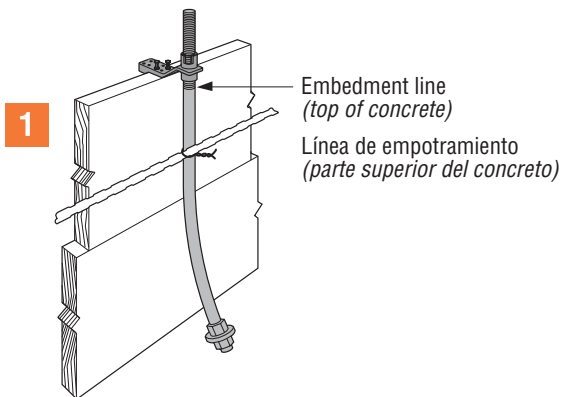

**Install a minimum 45° from either edge**  
**Instalar a mínimo 45° de cada cara**

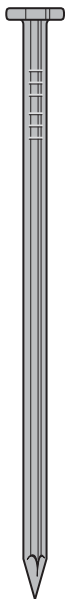

10d  
(0.148" x 3")

1

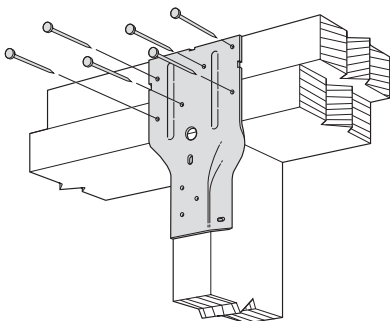

2

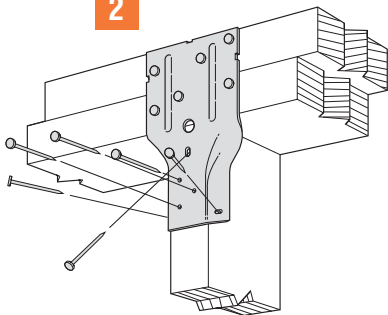

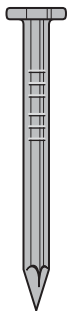

**10d x 1½"**  
**(0.148" x 1½")**

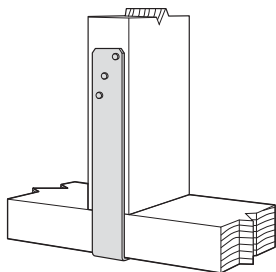
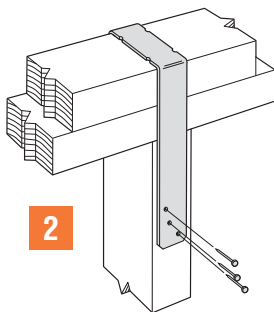
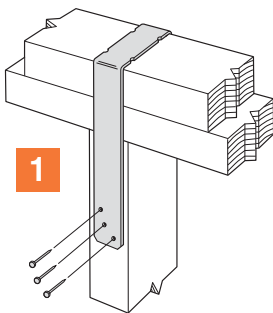

**Installation on mudsill/bottom  
plate similar**

**Instalación en solera/similar a la  
placa inferior**

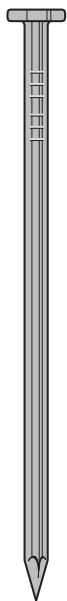

**10d**  
**(0.148" x 3")**

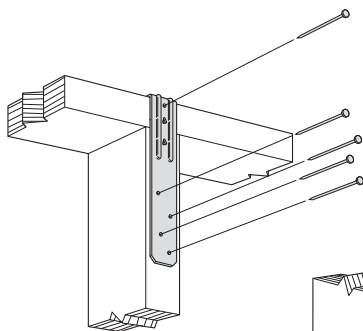

**Installation on mudsill/  
bottom plate similar**

**Instalación en  
solera/similar a  
la placa inferior**

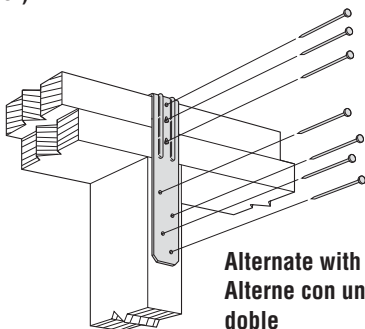
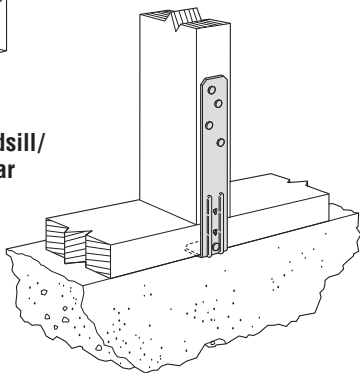

**Alternate with double top plate**  
**Alterne con una placa superior  
doble**

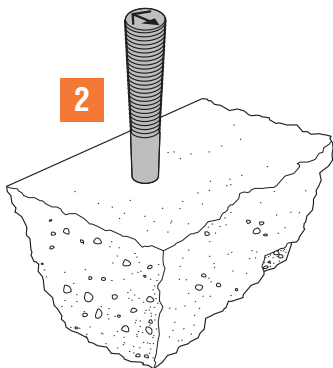
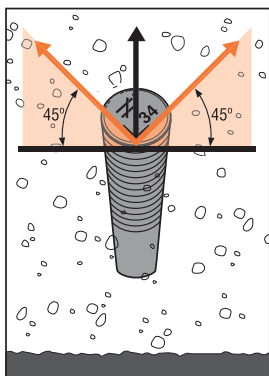
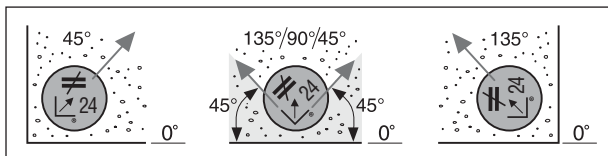
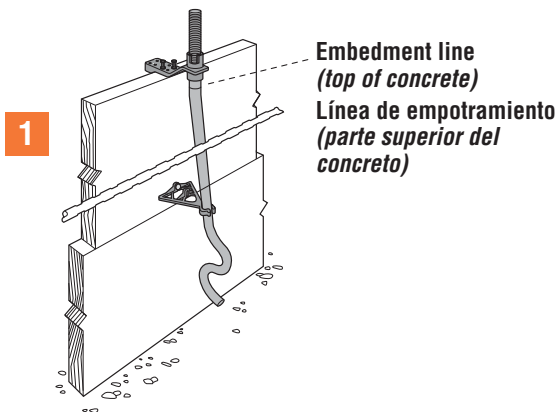

**Install 45° from either edge**  
**Instalar 45° de cada cara**

# STHD – w/StrapMate®

**SIMPSON**  
**Strong-Tie**

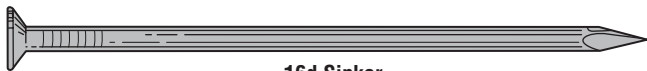

**16d Sinker**  
**(0.148" x 3¼")**

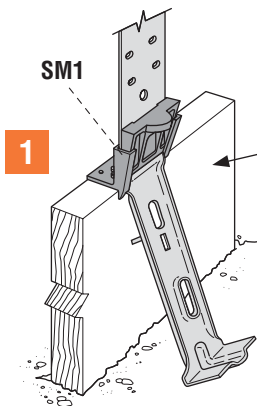

**1**

**SM1**

**Embedment line**  
**(top of concrete)**

**Línea de empotramiento**  
**(parte superior del**  
**concreto)**

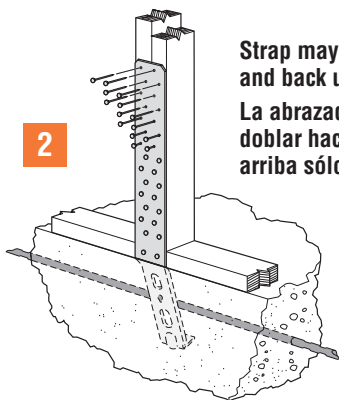

**2**

**Strap may be bent down**  
**and back up one time only**

**La abrazadera se puede**  
**doblar hacia abajo y hacia**  
**arriba sólo una vez**

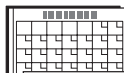

**Concrete MUST cure**  
**El concreto DEBE curar**



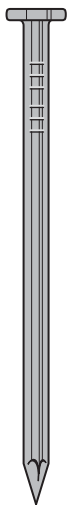

**8d**  
**(0.131" x 2 1/2")**

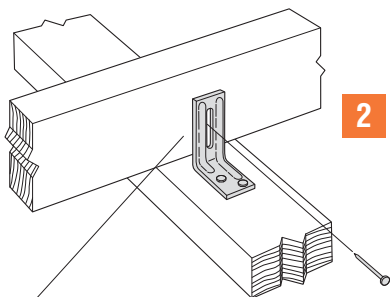
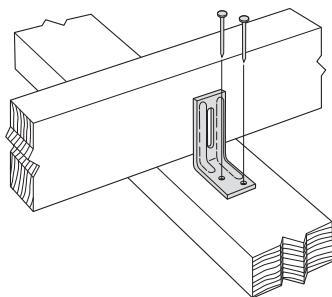

**Install nail in center of slot**  
**Instale el clavo en el centro**  
**de la ranura**

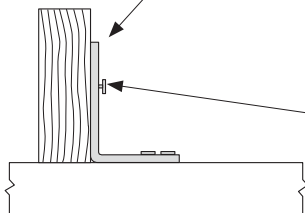

**Truss nails not driven flush**  
**Los clavos de la cercha no**  
**deberían asentarse contra**  
**el conector**

# SUR/L

**SIMPSON**  
**Strong-Tie**

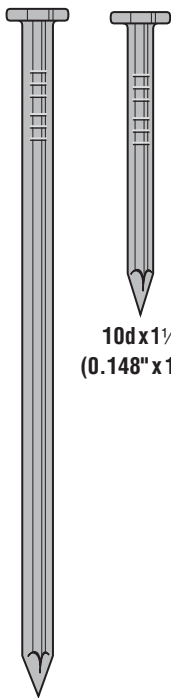

**10d x 1½"**  
**(0.148" x 1½")**

**16d**

**(0.162" x 3½")**

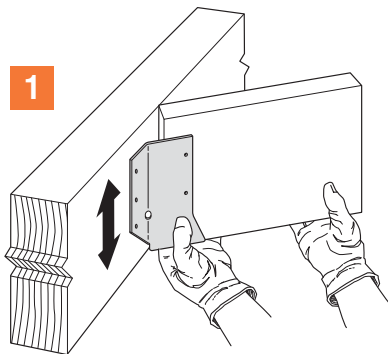

**2**

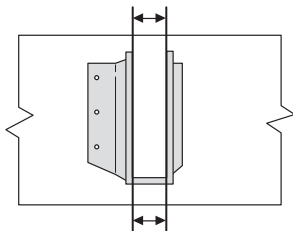
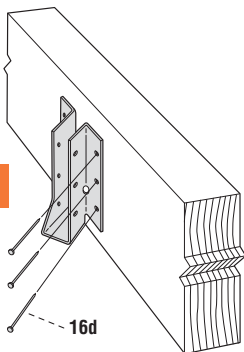

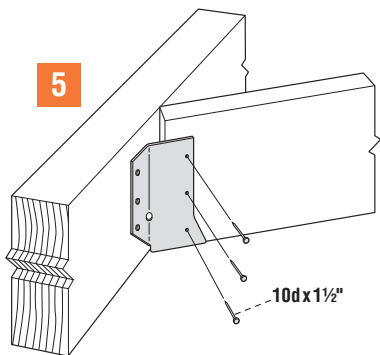
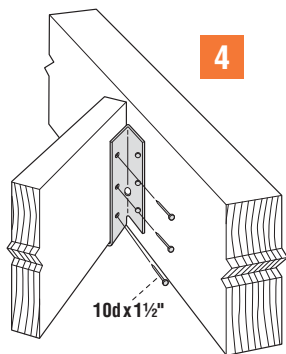
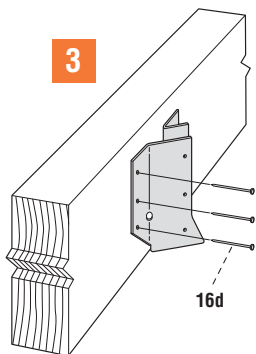

## Top-Mount Condition / Condición de Montaje Superior

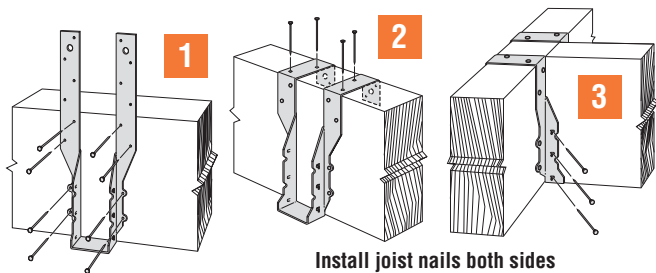

Install joist nails both sides  
Instale clavos para vigas a ambos lados

## Face Mount Condition / Condición de Montaje Sobre Cara

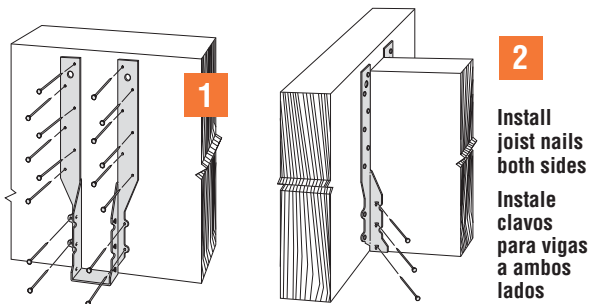

Install joist nails both sides  
Instale clavos para vigas a ambos lados

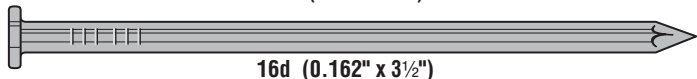
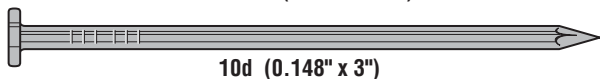
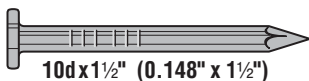

## Installation on Solid Header Instalación Sobre Viga Cabezal Sólida

Model Modelo	Top & Face Encima & Cara	Carried Member Miembro Soportado
THA29	16-10d	4-10d
THA213	14-10d	4-10d
THA413		
THA218	18-10d	4-10d
THA218-2	22-16d	6-16d
THA418		
THA422		
THA222-2		
THA422-2	30-16d	6-16d
THA426		

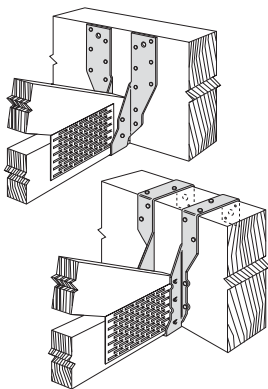

Double 2x4 Top Chord Min.  
Viga Superior Doble de 2 x 4 Como Mínimo

## Installation on Truss Instalación Sobre Cercha

Nail Location Ubicación de Los Clavos	Qty / Nail Cant./Clavo
Top / Encima	4-16d
Face / Cara	4-16d
Carried Member Miembro soportado	Fill all holes with 16d Llene todos los orificios con clavos 16d.

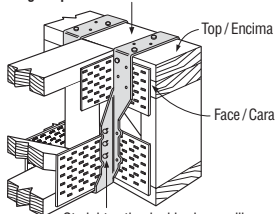

Straighten the double shear nailing tabs and install nails straight  
Enderece las pestañas de clavado de doble penetración e instale los clavos rectos.

## Installation on Nailer Instalación en Listón Clavador

Nail Location Ubicación de Los Clavos	4x Nailer / Listón Clavador 4x
Top / Encima	4-16d
Face / Cara	4-16d
Carried Member Miembro soportado	Fill all holes with 16d Llene todos los orificios con clavos 16d.

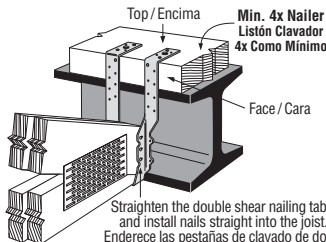

Straighten the double shear nailing tabs and install nails straight into the joist.  
Enderece las pestañas de clavado de doble penetración e instale los clavos rectos en la viga.

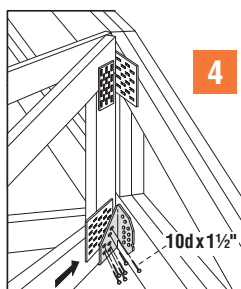
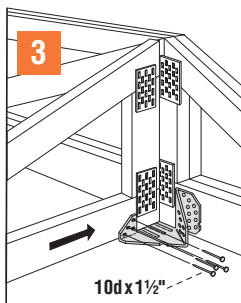
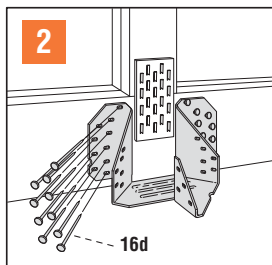
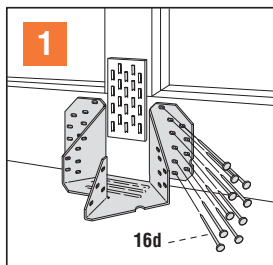
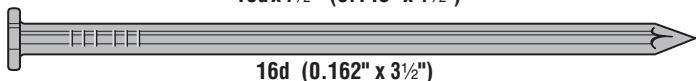
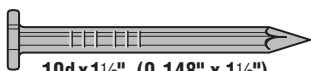

Left hand hip  
installation similar  
Similar a la instalación  
'izquierda' de cumbre

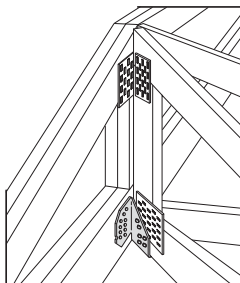



10d (0.148" x 3")

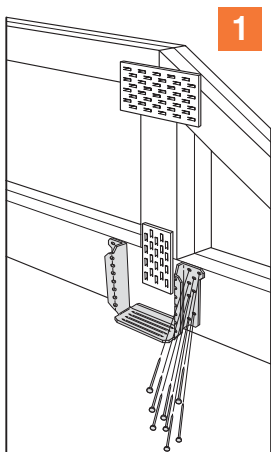

1

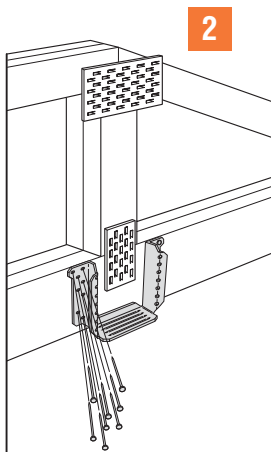

2

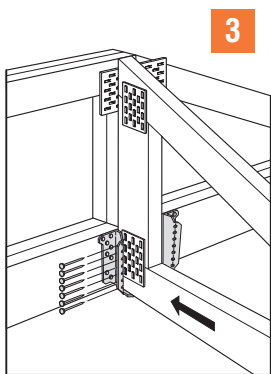

3

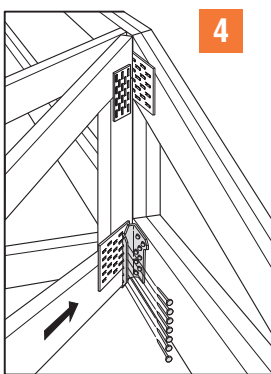

4

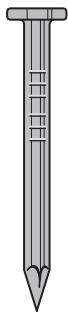

**10d x 1½"**  
**(0.148" x 1½")**

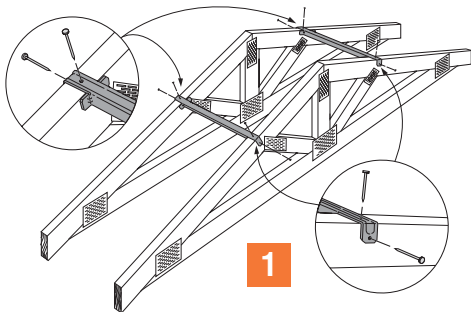

**1**

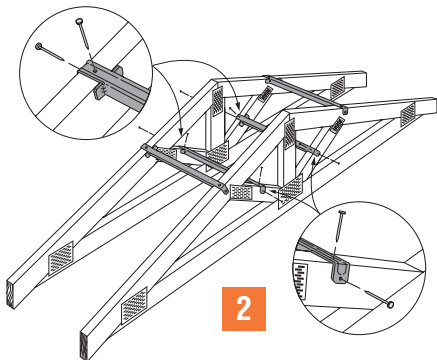

**2**

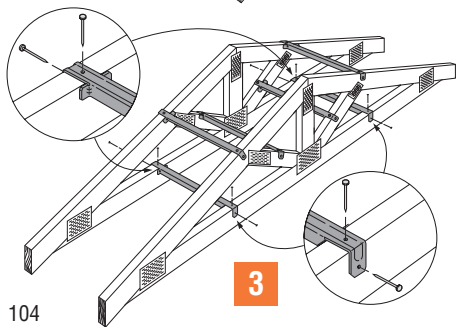

**3**

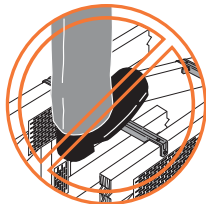

**NO STEP**  
**NO PISAR**



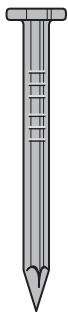

10d x 1½"  
(0.148" x 1½")

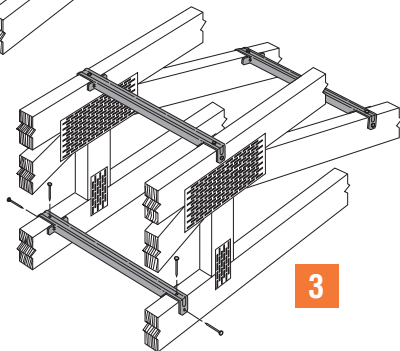
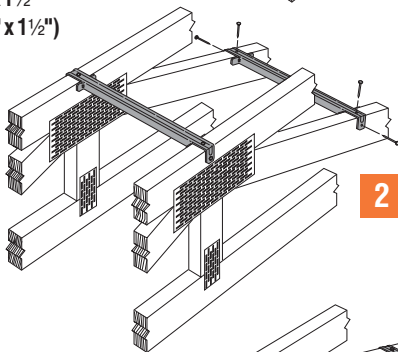
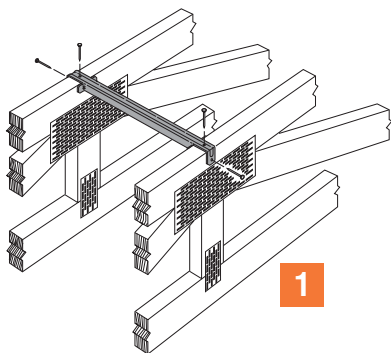

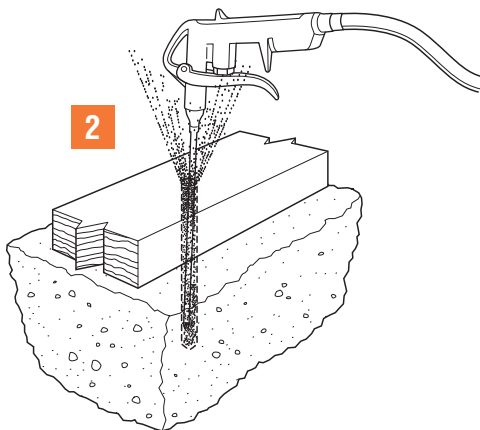
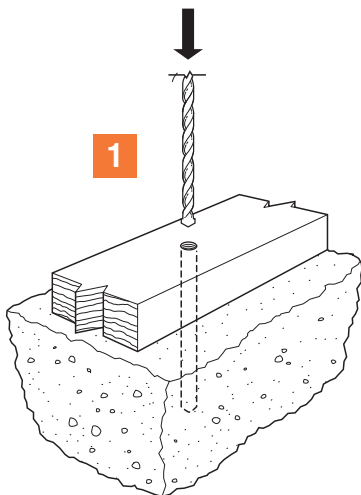

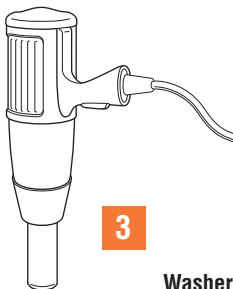

**3**

**Washer or bearing plate as  
required by building code**

**Arandela o disco de presión  
según lo requiera el código  
de construcción**

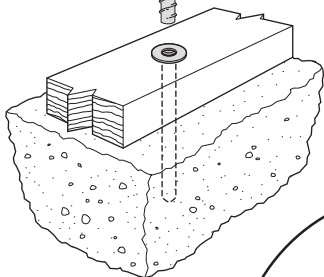

**4**

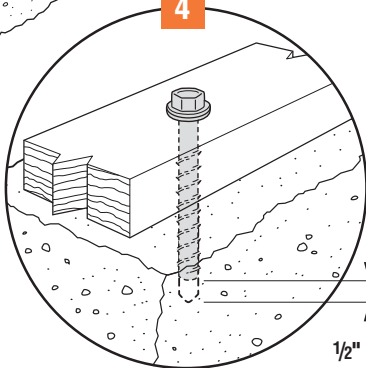

**1/2" min.**

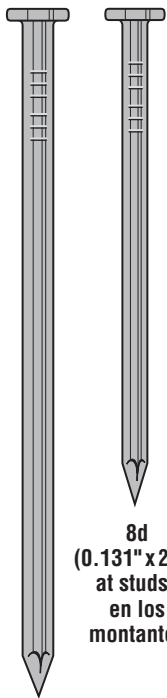

**8d**  
(0.131" x 2½")  
at studs /  
en los  
montantes

**16d**  
(0.162" x 3½")  
at plates /  
en las soleras

Cut 5/8" kerf  
Corte un corte  
de 5/8"

**1**

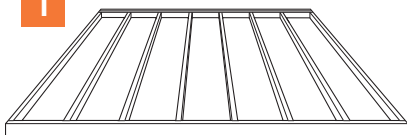

**2**

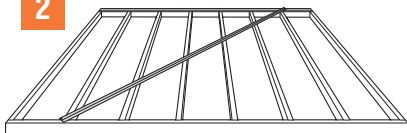

**3**

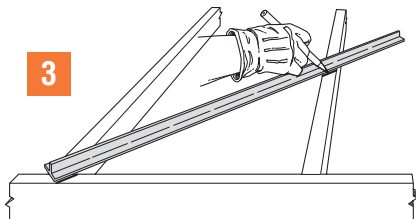

**4**

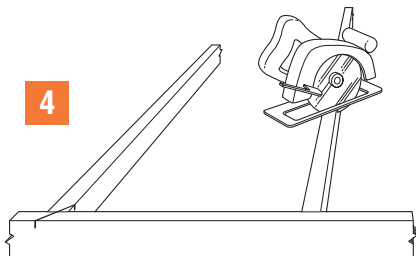

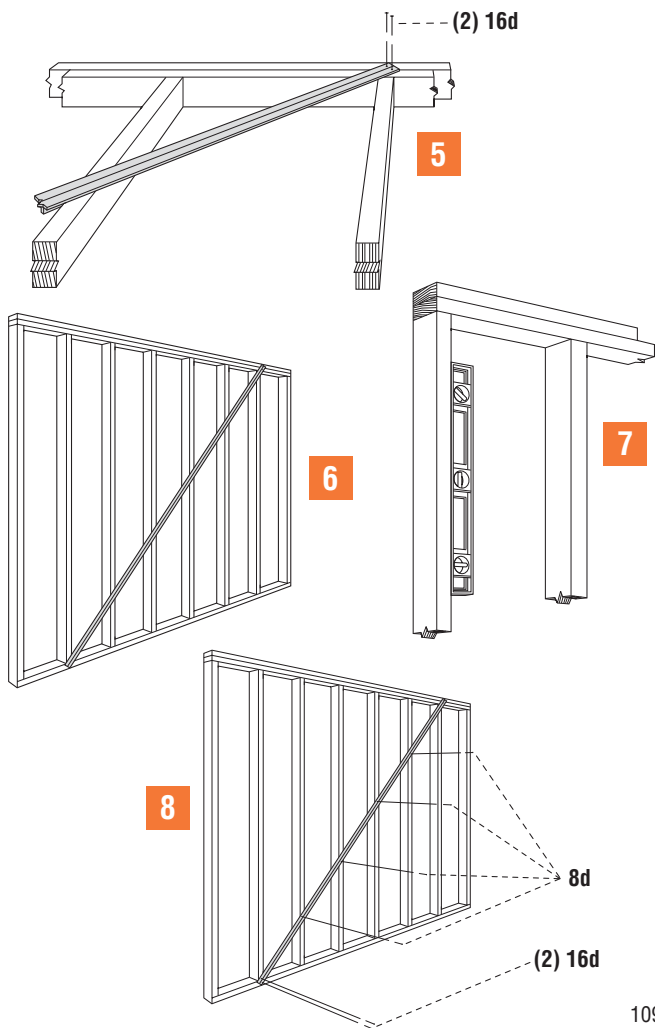

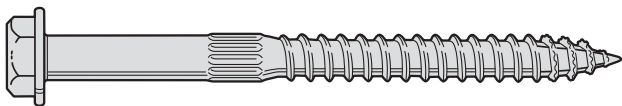

**SDS 1/4" x 3"**

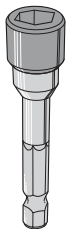

**Use 3/8" driver**  
**Use un**  
**destornillador**  
**de 3/8"**

**If using an adhesive anchor,**  
**see page 24 for instructions.**

**Si utiliza un anclaje adhesivo,**  
**consulte las instrucciones de**  
**la página 24.**

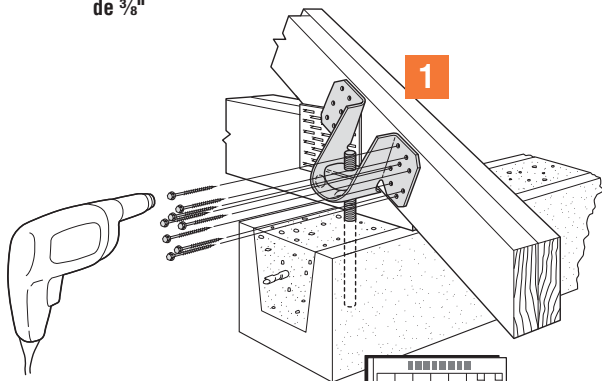

**Concrete MUST cure**  
**El concreto DEBE curar**

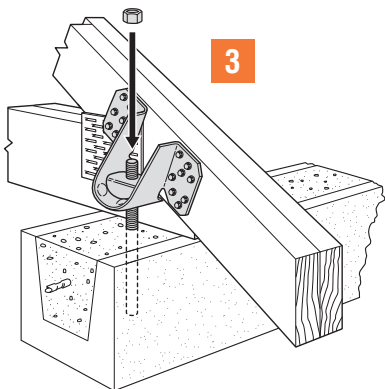
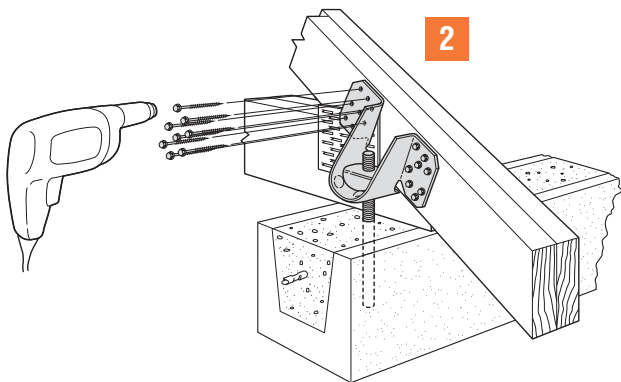

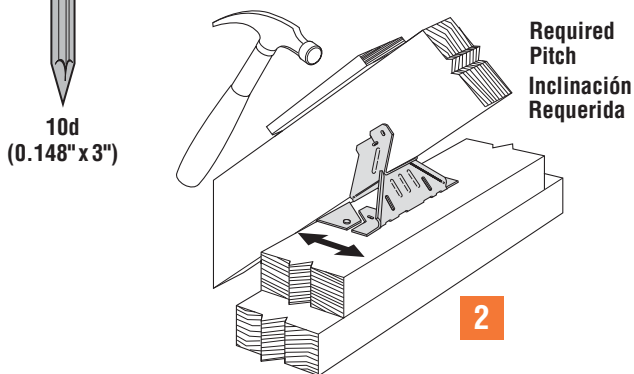
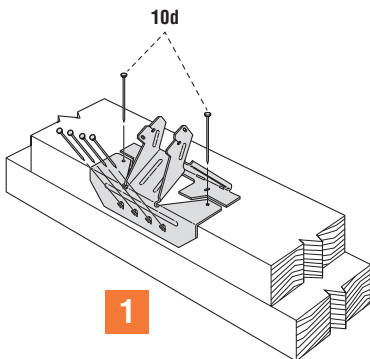
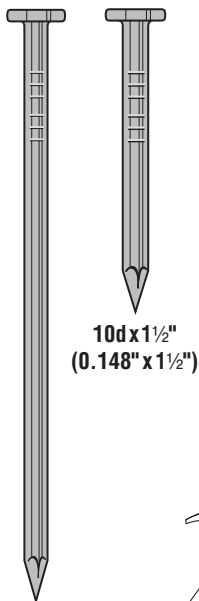



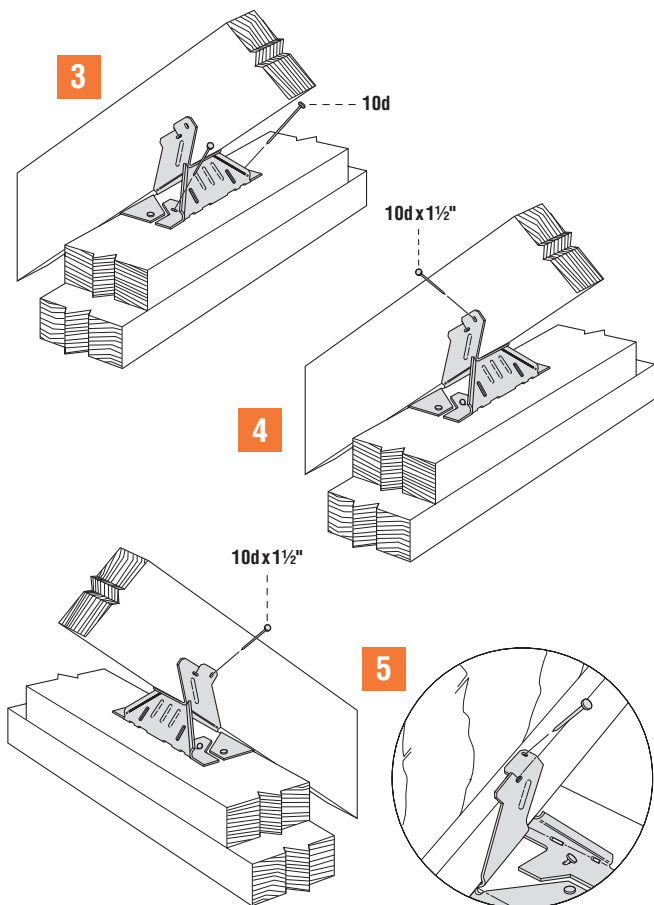

**Solid Wood**  
**Madera Sólida**

**I-Joist**  
**Vigueta**













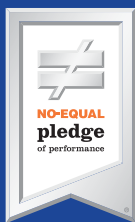

Every day we work hard to earn your business, blending the talents of our people with the quality of our products and services to exceed your expectations. This is our pledge to you.

Nos esforzamos fuerte diariamente combinando el talento de nuestro personal con la calidad de nuestros productos y servicios excediendo sus expectativas para tenerlo a usted como cliente. Este es nuestro compromiso para con usted.

---

**800-999-5099**  
**[www.strongtie.com](http://www.strongtie.com)**

S-C-INSTALL14 2/14 exp. 6/15

© 2014 Simpson Strong-Tie Company Inc.