

ENGINEERED WOOD PRODUCTS

WOOD—THE MIRACLE MATERIAL Wood is the right choice for a host of construction applications. It is the earth's natural, energy efficient and renewable building material.

ENGINEERED WOOD IS A BETTER USE OF WOOD We're growing more wood every day. Forests fully cover one-third of the United States' and one-half of Canada's land mass. American landowners plant more than two billion trees every year.

In addition, millions of trees seed naturally. The forest products industry, which comprises about 15 percent of forestland ownership, is responsible for 41 percent of replanted forest acreage. That works out to more than one billion trees a year, or about three million trees planted every day. This high rate of replanting accounts for the fact that each year, 27 percent more timber is grown than is harvested. Canada's replanting record shows a fourfold increase in the number of trees planted between 1975 and 1990.

Life Cycle Assessment shows wood is the greenest building product. A 2004 CORRIM study gave scientific validation to the strength of wood as a green building product. In examining building products' life cycles—from extraction of the raw material to demolition of the building at the end of its long lifespan—CORRIM found that wood was better for the environment than steel or concrete in terms of embodied energy, global warming potential, air emissions, water emissions, and solid waste production. For the complete details of the report, visit www.CORRIM.org.

Manufacturing wood is energy efficient. Wood products made up 47 percent of all industrial raw materials manufactured in the United States, yet consumed only 4 percent of the energy needed to manufacture all industrial raw materials.

Good news for a healthy planet. For every ton of wood grown, a young forest produces 1.07 tons of oxygen and absorbs 1.47 tons of carbon dioxide.

Wood—the miracle material for the environment, for design, and for strong, lasting construction.

The miracle in today's wood products is that they make more efficient use of the wood fiber resource to make stronger plywood, oriented strand board, I-joists, glued laminated timbers and laminated veneer lumber. That's good for the environment, and good for designers seeking strong, efficient and striking building design.

OUR PRODUCT WARRANTY

Pacific Woodtech Corporation warrants that its products, as manufactured, will be free from manufacturing errors or defects in workmanship and material. In addition, provided the product, as manufactured, is correctly installed and used, Pacific Woodtech Corporation warrants the adequacy of its design for the normal and expected life of the structure. This warranty is backed by the full resources of Pacific Woodtech Corporation and by underwritten product liability insurance.

LIMITED LIFETIME WARRANTY

Pacific Woodtech Corporation warrants that PWT-I and PWT-LVL products are free of defects in material and workmanship, as manufactured, and, when stored, installed and finished in accordance with Pacific Woodtech Corporation's published installation instructions, will perform as specified in the current published specifications for the expected lifetime of the structure in which they are installed.

LIMITATIONS

Pacific Woodtech Corporation must be given reasonable prior notice and opportunity to inspect the product before it will honor any claims under this warranty. If, after inspection and confirmation of the problem, Pacific Woodtech Corporation determines that there is a failure covered by the above warranty, Pacific Woodtech Corporation will repair or replace (at its option) the product at its expense. The product must be stored, handled and installed in accordance with Pacific Woodtech Corporation's current published installation instructions and design specifications. Failure to follow such instructions will void this warranty. The product must be stored in accordance with recommended procedures and protected from incidental exposure to moisture from whatever source by proper building standards.

DISCLAIMER

The limited lifetime warranty set forth above is exclusive and in lieu of any other warranty or guarantee, expressed or implied, including but not limited to any warranties of merchantability or fitness for a particular purpose. Correction of defects in the manner and under the conditions stated above shall constitute the fulfillment of all Pacific Woodtech Corporation's obligations and liabilities to any person with respect to the product, as manufactured, whether based on contract, negligence, strict liability or otherwise. No person or entity is authorized to create for Pacific Woodtech Corporation any other obligation or liability to any person relating to the product. In no event shall Pacific Woodtech Corporation be liable for indirect, special, incidental or consequential damages of any kind sustained from any cause.

I-JOIST AND LVL INSTALLATION GUIDE



SAFETY AND CONSTRUCTION PRECAUTIONS

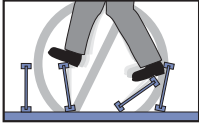

Do not allow workers to walk on I-joists until joists are fully installed and braced, or serious injuries can result.

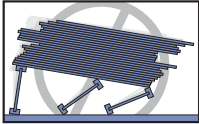

Never stack building materials over unsheathed I-joists. Stack only over beams or walls.

Improper storage or installation, failure to follow applicable building codes, failure to follow span ratings for I-joists, failure to use allowable hole sizes and locations, or failure to use web stiffeners when required can result in serious accidents. Follow these installation guidelines carefully.

THESE ARE GENERAL RECOMMENDATIONS AND IN SOME CASES, ADDITIONAL PRECAUTIONS MAY BE REQUIRED.

INSTALLATION

- Walking on the joists should not be permitted until they are properly braced.
- All hangers, rim boards, rim joists and blocking at the end supports of the joists must be installed and nailed properly.
- During installation, a minimum of 1 x 4 temporary bracing is required.
- Bracing members should be spaced at 8'–0" o.c. and nailed to each joist with two 8d nails (10d box nails if bracing thickness exceeds 1").
- Lap bracing ends and anchor them to temporary or permanent sheathing nailed to the first 4' of joists at the end of the bay or a braced end wall.
- Do not cut, drill, or notch flanges.
- The ends of cantilevers must be temporarily braced on both the top and bottom flanges.
- Never overload sheathed joists with loads that exceed design loads.
- Only remove the bracing as the sheathing is attached.
- Engineered wood products should be used in dry conditions only.
- When stacking construction material, stack only over beams or walls, NOT on unsheathed joists.

STORAGE AND HANDLING GUIDELINES

STORAGE

- Store bundles upright on a smooth, level, well drained supportive surface.
- Always stack and handle I-joists in the upright position only.
- Bundles should not be in contact with the ground.
- Place 2x or LVL spacers (at a maximum of 10' apart) between bundles and the ground and bundles stored on top of one another.
- Bundles should remain wrapped, strapped and protected from the weather until time of installation.

HANDLING

- All handling of joists with a forklift or crane should be done carefully.
- Joists should remain vertical during handling.
- Avoid excessive bowing during all phases of handling and installation (i.e. measuring, sawing or placement).
- Damage may result if the joist or beam is twisted or a load is applied to it while it's lying flat.
- NEVER USE OR FIELD REPAIR A DAMAGED I-JOIST.

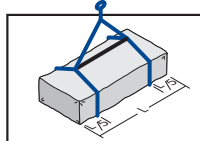
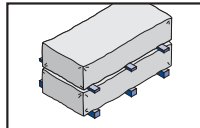
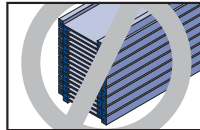
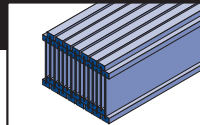

INSTALLATION NOTES

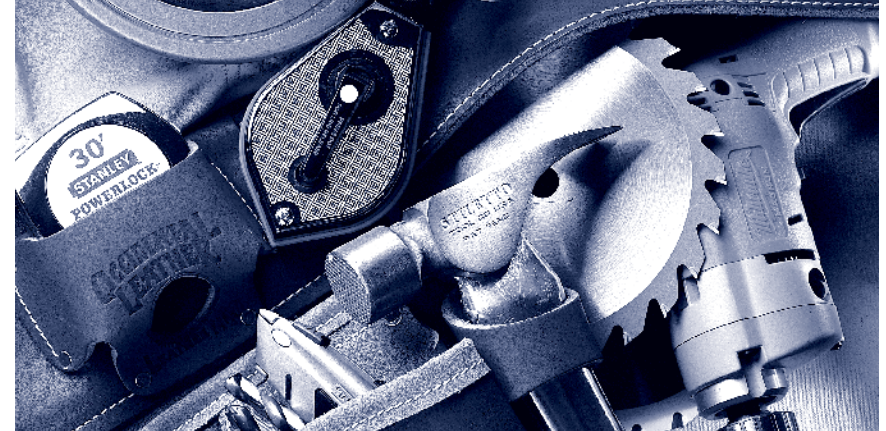

1. I-joists and laminated veneer lumber shall be used in protected, dry-use conditions only. Separation from concrete and masonry shall be as provided in the local building code for wood that is not treated and not naturally durable.
2. I-joists may be cut to length or cut as shown in this guide, otherwise I-joist flanges shall not be cut, notched or drilled. Holes may be cut in the I-joist web as shown in WEB HOLE SPECIFICATIONS.
3. Laminated veneer lumber (LVL) may be cut to length, ripped to depth or trimmed as shown in this guide, otherwise LVL shall not be cut, notched or drilled. Holes may be drilled in LVL as shown in HOLE DETAILS.
4. The minimum allowable I-joist bearing length is 1¾ inches at end supports and 3½ inches at intermediate supports. The minimum allowable laminated veneer lumber bearing length is 1½ inches at both end and intermediate supports. Longer bearing lengths might be required by the building designer.
5. I-joists and laminated veneer lumber shall be supported laterally in accordance with local building code provisions for wood framing members, except that bridging is not required in floor joist spans.
6. Hangers and other metal connectors shall be installed in accordance with the connector manufacturer's installation instructions.
7. Rim boards, rim joists, blocking panels or squash blocks shall be installed at I-joist supports where load-bearing walls are located directly above the supports.
8. I-joists shall be installed straight (½ inch maximum deviation) and plumb.
9. Suspended loads should generally be attached to the joist web through filler blocks. Light loads may be suspended from the bottom flange. Refer to the building designer's installation instructions.
10. Sheathing shall be fastened to I-joists and laminated veneer lumber in accordance with local building code provisions for wood framing members and the building designer's installation instructions.

NAIL SPACING FOR ATTACHMENT OF SHEATHING TO I-JOISTS^(1, 2)

Flange Width, b	Minimum Nail Spacing Per Row		Maximum Nail Spacing Any Nail Diameter
	Nail Diameter ≤ 0.128 inches ⁽³⁾	Nail Diameter ≤ 0.148 inches ⁽⁴⁾	
b < 1¾ inches	3 inches	3 inches	18 inches
b = 1¾ inches	2 inches	3 inches	18 inches
b > 1¾ inches	2 inches	3 inches	24 inches

1. If more than one row of nails is required, the rows must be offset by at least ½ inch and staggered.
2. Do not use nails with diameters larger than 0.148 inches.
3. 6d common, 10d box, 10d sinker and smaller
4. 10d common, 20d box, 16d sinker and smaller

ALLOWABLE RESIDENTIAL FLOOR SPANS

ALLOWABLE SPANS FOR I JOISTS – 40 PSF LIVE LOAD AND 10 PSF DEAD LOAD

I-Joist Series	I-Joist Depth	SIMPLE SPAN				MULTIPLE SPAN			
		12" o.c.	16" o.c.	19.2" o.c.	24" o.c.	12" o.c.	16" o.c.	19.2" o.c.	24" o.c.
PWI-20	9 1/2"	16'-8"	15'-3"	14'-5"	13'-6"	18'-6"	17'-0"	15'-7"	13'-11"
	11 7/8"	19'-11"	18'-3"	17'-3"	16'-0"	22'-3"	19'-6"	17'-10"	15'-8"
PWI-30	14"	22'-8"	20'-9"	19'-6"	17'-5"	24'-8"	21'-4"	19'-6"	15'-8"
	9 1/2"	17'-1"	15'-8"	14'-10"	13'-10"	19'-0"	17'-5"	16'-5"	15'-0"
PWI-40	11 7/8"	20'-6"	18'-9"	17'-9"	16'-7"	22'-10"	20'-10"	18'-9"	15'-0"
	9 1/2"	18'-0"	16'-5"	15'-6"	14'-6"	20'-0"	17'-10"	16'-3"	14'-6"
PWI-45	11 7/8"	21'-5"	19'-7"	18'-6"	16'-8"	23'-7"	20'-4"	18'-7"	16'-7"
	14"	24'-4"	22'-3"	20'-6"	18'-4"	25'-11"	22'-5"	20'-5"	18'-3"
PWI-50	16"	26'-11"	24'-2"	22'-1"	19'-9"	27'-11"	24'-1"	22'-0"	19'-8"
	9 1/2"	18'-0"	16'-5"	15'-6"	14'-6"	20'-0"	18'-3"	17'-3"	16'-1"
PWI-55	11 7/8"	21'-5"	19'-7"	18'-6"	17'-3"	23'-11"	21'-10"	20'-6"	17'-9"
	14"	24'-4"	22'-3"	21'-0"	19'-5"	27'-2"	24'-7"	22'-3"	17'-9"
PWI-60	16"	27'-0"	24'-8"	23'-4"	19'-5"	30'-2"	26'-4"	22'-3"	17'-9"
	9 1/2"	17'-10"	16'-3"	15'-5"	14'-5"	19'-10"	18'-1"	17'-1"	15'-11"
PWI-65	11 7/8"	21'-4"	19'-6"	18'-5"	17'-2"	23'-9"	21'-8"	20'-2"	16'-1"
	14"	24'-4"	22'-2"	21'-0"	19'-7"	27'-1"	24'-3"	20'-2"	16'-1"
PWI-70	16"	27'-0"	24'-8"	23'-4"	20'-1"	30'-2"	24'-3"	20'-2"	16'-1"
	9 1/2"	18'-11"	17'-3"	16'-4"	15'-3"	21'-1"	19'-2"	18'-1"	16'-10"
PWI-75	11 7/8"	22'-7"	20'-8"	19'-6"	18'-2"	25'-2"	22'-11"	21'-8"	19'-6"
	14"	25'-8"	23'-5"	22'-2"	20'-8"	28'-8"	26'-1"	24'-0"	19'-9"
PWI-80	16"	28'-6"	26'-0"	24'-7"	22'-11"	31'-10"	28'-5"	24'-9"	19'-9"
	9 1/2"	23'-4"	21'-3"	20'-1"	18'-8"	26'-0"	23'-8"	22'-3"	18'-5"
PWI-85	11 7/8"	26'-5"	24'-2"	22'-9"	21'-3"	29'-6"	26'-10"	23'-1"	18'-5"
	14"	29'-3"	26'-9"	25'-2"	23'-0"	32'-8"	27'-9"	23'-1"	18'-5"
PWI-90	16"	32'-0"	29'-3"	27'-7"	23'-0"	35'-9"	27'-9"	23'-1"	18'-5"
	9 1/2"	34'-8"	31'-7"	28'-10"	23'-0"	37'-1"	27'-9"	23'-1"	18'-5"
PWI-95	11 7/8"	19'-8"	17'-11"	16'-11"	15'-10"	21'-11"	20'-0"	18'-10"	17'-7"
	14"	23'-5"	21'-4"	20'-2"	18'-10"	26'-1"	23'-9"	22'-5"	20'-11"
PWI-100	16"	26'-7"	24'-3"	22'-11"	21'-4"	29'-8"	27'-0"	25'-6"	21'-4"
	9 1/2"	29'-5"	26'-10"	25'-4"	23'-8"	32'-10"	29'-11"	26'-8"	21'-4"
PWI-105	11 7/8"	32'-2"	29'-4"	27'-9"	25'-6"	35'-11"	32'-1"	26'-8"	21'-4"
	14"	34'-10"	31'-10"	30'-0"	25'-6"	38'-11"	32'-1"	26'-8"	21'-4"
PWI-110	16"	37'-5"	34'-2"	32'-3"	30'-1"	41'-10"	38'-2"	35'-1"	31'-5"
	9 1/2"	40'-0"	36'-6"	34'-5"	32'-2"	44'-8"	40'-2"	36'-8"	32'-9"
PWI-115	11 7/8"	22'-2"	20'-2"	19'-0"	17'-8"	24'-8"	22'-5"	21'-1"	19'-8"
	14"	26'-5"	24'-0"	22'-7"	21'-1"	29'-5"	26'-9"	25'-2"	23'-4"
PWI-120	16"	29'-11"	27'-3"	25'-8"	23'-11"	33'-4"	30'-4"	28'-6"	26'-6"
	9 1/2"	33'-1"	30'-2"	28'-5"	26'-5"	36'-11"	33'-7"	31'-7"	26'-7"
PWI-125	11 7/8"	36'-2"	32'-11"	31'-0"	27'-10"	40'-4"	36'-8"	33'-3"	26'-7"
	14"	39'-2"	35'-8"	33'-7"	27'-10"	43'-8"	39'-9"	33'-3"	26'-7"
PWI-130	16"	42'-0"	38'-3"	36'-1"	33'-7"	46'-11"	42'-8"	40'-2"	36'-7"
	9 1/2"	44'-10"	40'-10"	38'-6"	35'-10"	50'-1"	45'-6"	42'-10"	36'-7"

Notes:

- Table values apply to uniformly loaded, residential floor joists.
- Span is measured from face to face of supports.
- Deflection is limited to L/240 at total load and L/480 at live load.
- Table values are based on glued and nailed sheathing panels (23/32" for 24" o.c., 19/32" otherwise). Use an ASTM D 3498 adhesive in accordance with the manufacturer's recommendations. Reduce spans by 12" if sheathing is nailed only.
- Provide at least 1 3/4" of bearing length at end supports and 3 1/2" at intermediate supports.
- Provide lateral restraint at supports (e.g. blocking panels, rim board) and along the compression flange of each joist (e.g. floor sheathing, gypsum board ceiling).
- Use sizing software or consult a professional engineer to analyze conditions outside the scope of this table (e.g. commercial floors, different bearing conditions, concentrated loads) or for multiple span joists if the length of any span is less than half the length of an adjacent span.

HOW TO USE FLOOR SPAN TABLES:

- Choose the appropriate live and dead load combination as well as a joist spacing.
- Scan down the spacing column to find a span that exceeds the design span.
- Scan to the left from that span to determine the joist size required.
- Web stiffeners are required at all supports for 22" and 24" joists. See *Web Stiffener Requirements* in this guide for more details.

FLOOR INSTALLATION DETAILS

FLOOR NOTES:

- Use min. 2 1/2" x 0.131" nails unless otherwise noted. Larger diameter nails might split flanges.
- Fasten joists to top plate with at least two nails. Start nails at least 1 1/2" from end to avoid splitting.
- Engineered projects might require higher strength connections. Refer to designer's specifications.
- 1 3/4" min. bearing at end supports. 3 1/2" at intermediate and cantilever supports.
- Framing lumber is assumed to be S-P-F unless otherwise noted.
- See *Web Stiffener Requirements* in this guide.
- Mid-span bridging is not required.

F1 END SUPPORT

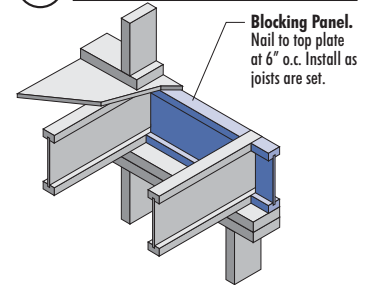

F2 END SUPPORT

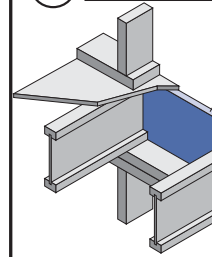

F4 INTERMEDIATE SUPPORT

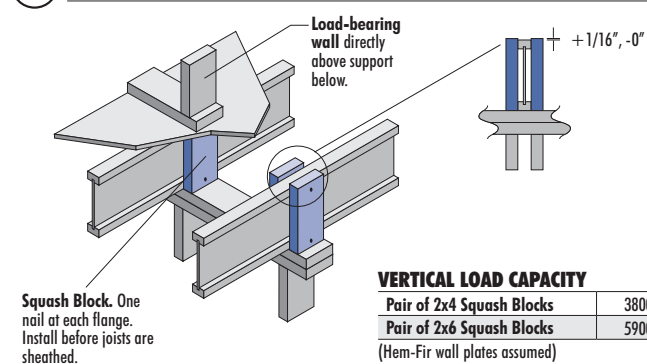

VERTICAL LOAD CAPACITY

Pair of 2x4 Squash Blocks	3800 lb
Pair of 2x6 Squash Blocks	5900 lb

(Hem-Fir wall plates assumed)

F5 AT COLUMNS

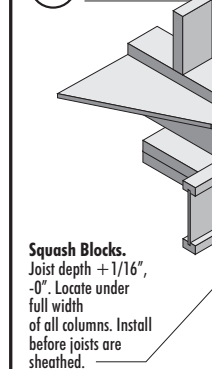

F8 FLOOR OPENING

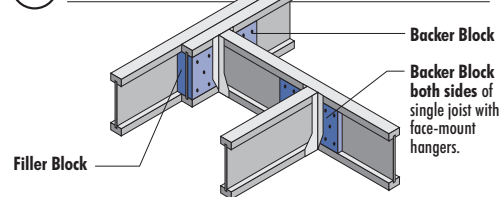

Side Load	Backer Nails	Filler Nails	Joist Flange Width	Filler Block Nail Length	Filler Thickness	Backer Thickness
500 lb	8	4	1 1/2"	2 1/2" min.	1 1/8" or 1 1/4"	1/2" or 5/8"
750 lb	12	6	1 3/4"	3" min.	1 1/2"	3/4"
1000 lb	16	8	1 7/8"	3" min.	1 3/4"	7/8"
1250 lb	20	10	2 1/16"	3" min.	1 3/4"	7/8"
1500 lb	24	12	2 5/16"	3 1/4" min.	2"	1"
1750 lb	28	14	2 1/2"	3 1/2" min.	2" or 2 1/4"	1" or 1 1/8"
2000 lb	32	16	3 1/2"	3" min. ea. side	3"	1 1/2"

Notes:

- Side Load is the concentrated load transferred by a joist hanger.
- Use min. 0.131" diameter nails. For backer blocks, use 2 1/2" nails. For filler blocks, use length shown in table. Note that some joists require filler block nailing from each side.
- Use Sheathing grade panels, Utility grade S-P-F lumber, or better. Thinner blocks may be combined to achieve specified thicknesses.
- Size and position blocks to receive all nails, including hanger nails, without splitting.
- Max. block depth is joist depth minus 3/8" to avoid an interference fit between flanges.
- For top-mount hangers, install backer blocks snug to top flange.
- Cinch nails when possible.
- Attach hangers according to manufacturer's instructions.

F9 AT WOOD BEAM

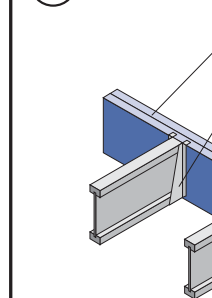

Rim Board.
One nail per flange.
Toe-nail to top plate at 6" o.c. Install as joists are set.

F3 END SUPPORT

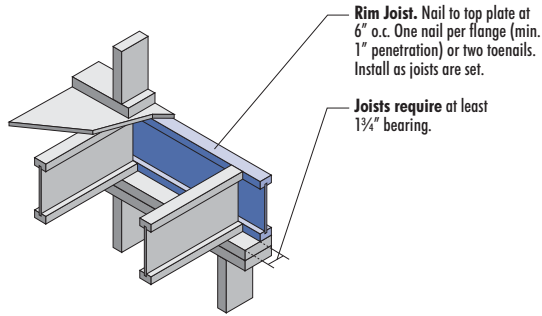

F6 END WALL

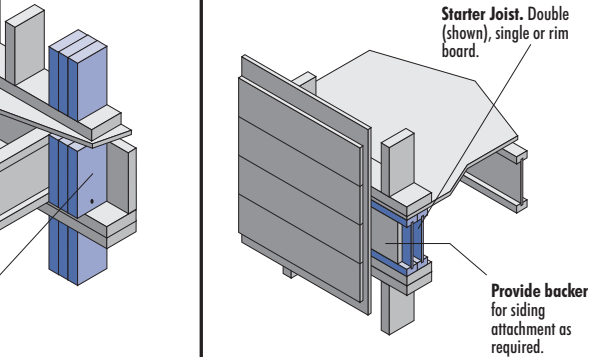

F7 INTERMEDIATE SUPPORT

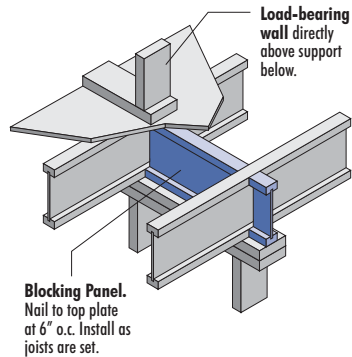

F10 AT MASONRY WALL OR STEEL BEAM

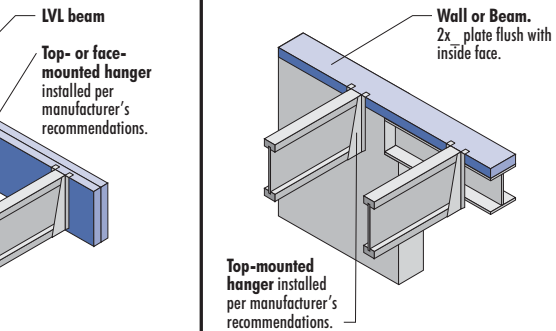

F11 BEVELED CUT

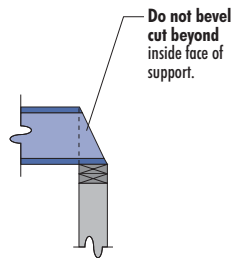

CANTILEVER DETAILS AND REINFORCEMENT

F12 INTERIOR BALCONY

Uniform loads only.

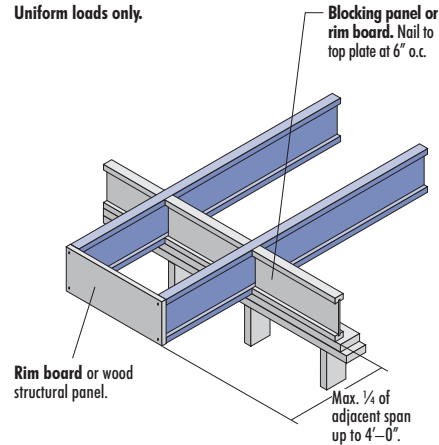

F13 EXTERIOR BALCONY

Min. 2x8. Preservative-treated as required. 2 rows of 3" x 0.148" nails at 6" o.c. Clinch when possible.

Uniform loads only. 60 psf live load max.

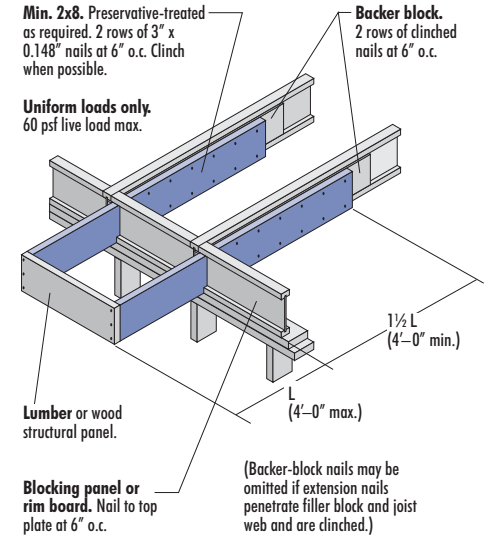

F14 REINFORCED CANTILEVER

Method 1—SHEATHING ONE SIDE

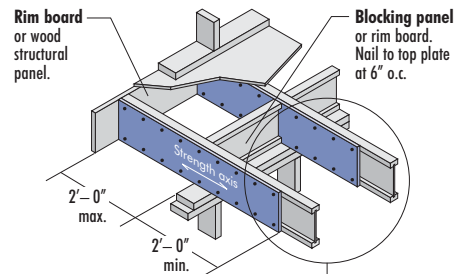

Method 2—SHEATHING TWO SIDES

Stagger nails from opposite sides to avoid flange splitting.

Method 1 and 2: Min. 23/32" sheathing-grade panels. Strength axis parallel to joist length. Reinforcement depth = joist depth. Nail to flanges at 6" o.c.

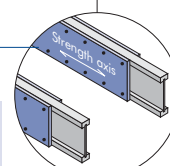

F15 REINFORCED CANTILEVER

Alternate Method 2—I-JOIST ONE SIDE

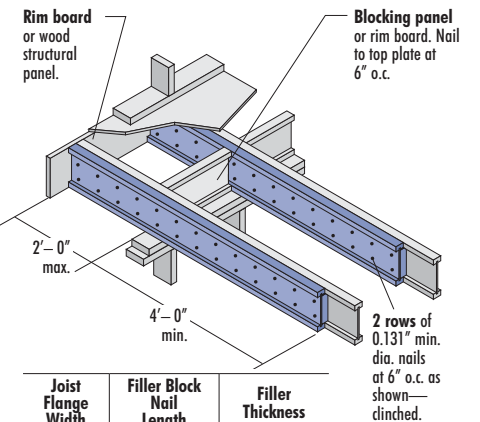

Joist Flange Width	Filler Block Nail Length	Filler Thickness
1 1/2"	2 1/2" min.	1 1/8" or 1 1/4"
1 3/4"	3" min.	1 1/2"
2 1/8"	3" min.	1 3/4"
2 3/16"	3 1/4" min.	2"
2 1/2"	3 1/2" min.	2" or 2 1/4"
3 1/2"	3" min. each side	3"

CANTILEVER REINFORCEMENT

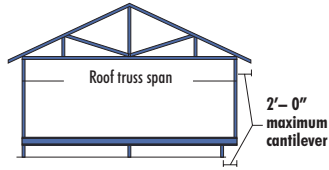

JOISTS WITH 3/8" WEBS

Roof Truss	9 1/2" Joist	11 7/8" Joist	14" Joist	16" Joist
Span (ft)	12" o.c.	16" o.c.	19 1/2" o.c.	24" o.c.
26	0	0	0	1
28	0	0	1	1
30	0	0	1	1
32	0	0	1	2
34	0	0	1	2
36	0	0	1	2
38	0	0	1	2
40	0	1	1	2
42	0	1	2	X
26	0	0	1	2
28	0	0	1	2
30	0	1	1	X
32	0	1	2	X
34	0	1	2	X
36	0	1	2	X
38	0	1	2	X
40	0	1	2	X
42	0	2	X	X
26	0	1	2	X
28	0	1	2	X
30	0	1	2	X
32	0	1	2	X
34	0	2	X	X
36	1	2	X	X
38	1	2	X	X
40	1	2	X	X
42	1	X	X	X

JOISTS WITH 7/16" WEBS

Roof Truss	9 1/2" Joist	11 7/8" Joist	14" Joist	16" Joist
Span (ft)	12" o.c.	16" o.c.	19 1/2" o.c.	24" o.c.
26	0	0	0	0
28	0	0	0	0
30	0	0	0	0
32	0	0	1	0
34	0	0	1	0
36	0	0	1	0
38	0	0	1	0
40	0	0	1	0
42	0	0	2	0
26	0	0	1	0
28	0	0	1	0
30	0	0	1	0
32	0	0	2	0
34	0	0	2	0
36	0	1	X	0
38	0	1	X	0
40	0	1	X	0
42	0	1	2	X
26	0	0	2	0
28	0	0	2	0
30	0	0	1	X
32	0	0	1	X
34	0	1	2	X
36	0	1	2	X
38	0	1	2	X
40	0	1	2	X
42	0	1	X	X

- Notes:**
- 0 = No reinforcement and no web stiffeners are required.
 - WS = Web stiffeners are required at the support. Follow the intermediate support web stiffener nailing requirements in this guide.
 - 1 = Reinforcer required on one side of the cantilever. See Method 1 detail in Cantilever Reinforcement section.
 - 2 = Reinforcers required on both sides of the cantilever. See Method 2 or Alternate Method 2 detail in Cantilever Reinforcement section.
 - X = Consider deeper joists or closer spacing.

Table values apply to joists sized by means of the 10 psf dead load allowable residential floor spans tables and are based on uniform loads across the ends of the cantilevers that include a 15 psf roof dead load and a 100 plf exterior wall load. Uniform loading may be assumed when window and door openings are up to three feet wide and spaced at least three feet apart. Otherwise, consider the need for extra joists under the window and door header jack studs.

Use sizing software or consult a professional engineer for conditions beyond the scope of this table.

WEB STIFFENER REQUIREMENTS

- Web stiffeners are required at the ends of joists set in hangers that are not deep enough to laterally support the top flanges of the joists. Refer to the hanger manufacturer's installation instructions.
- Web stiffeners are required to accommodate special hanger nailing requirements. Refer to the hanger manufacturer's installation instructions.
- Web stiffeners are required at birdsmouth cuts at the low end supports of sloped joists.
- Web stiffeners are required at all supports on 22- and 24-inch joists.
- Web stiffeners are required for high reactions at supports. Refer to the building designer's installation instructions.
- Web stiffeners are required under concentrated loads applied to the tops of joists between supports, or along cantilevers beyond the support, when the concentrated load exceeds 1500 pounds. Refer to the building designer's installation instructions.

NUMBER OF WEB STIFFENER NAILS REQUIRED

Joist Depth	24" & 22"	20" & 18"	16" & Less
Intermediate Support	10	8	4
All Other Conditions	8	6	4

WEB STIFFENER SIZE REQUIRED

Flange Width	Minimum Dimensions		Nails
	Thickness	Width	
1 1/2"	15/32"	2 5/16"	2 1/2" x 0.131"
1 3/4"	19/32"	2 5/16"	2 1/2" x 0.131"
2 1/16"	23/32"	2 5/16"	2 1/2" x 0.131"
2 5/16"	7/8"	2 5/16"	2 1/2" x 0.131"
2 1/2"	7/8"	2 5/16"	2 1/2" x 0.131"
3 1/2"	1 1/2"	3 1/2"	3 1/2" x 0.131"

Web stiffener length is approximately 1/8" less than the clear distance between flanges.

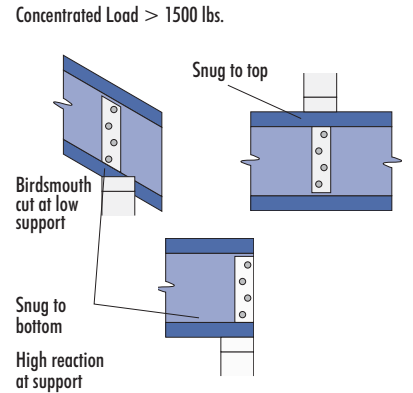

PRODUCT IDENTIFICATION

Joist Depth: 11 7/8"

Joist Series: PWI-40

Evaluation Report Numbers: ESR-1225, PR-L262, ESR-1405, CCMC 13470-R, ASTM D 5055, PR-E730 G5, LADBS RR 25450, FL7428, HUD SEB 1132

Mill Number: 1048

Manufacture Date Code: 08B12

Inspection Agency Trademark: PACIFIC WOODTECH

WEB HOLE SPECIFICATIONS

DUCT HOLES

		Minimum Distance 'D' From Any Support to the Centerline of the Hole				
Joist Series	Joist Span (ft)	Duct Hole Width				
		8"	10"	12"	14"	16"
PWI-20	8	3'-7"	3'-8"	3'-9"		
	12	5'-5"	5'-7"	5'-8"		
	16	7'-3"	7'-5"	7'-7"		
	20	9'-1"	9'-4"	9'-6"		
PWI-30	8	3'-9"	3'-10"	3'-11"		
	12	5'-8"	5'-9"	5'-11"		
	16	7'-7"	7'-8"	7'-10"		
	20	9'-5"	9'-8"	9'-10"		
PWI-40	8	3'-7"	3'-8"	3'-10"	3'-11"	
	12	5'-5"	5'-7"	5'-9"	5'-10"	
	16	7'-3"	7'-5"	7'-8"	7'-10"	
	20	9'-1"	9'-4"	9'-7"	9'-9"	
	24	10'-11"	11'-2"	11'-6"	11'-9"	
	28	12'-8"	13'-1"	13'-5"	13'-8"	
PWI-45	8	3'-5"	3'-7"	3'-8"	3'-9"	3'-10"
	12	5'-2"	5'-4"	5'-6"	5'-8"	5'-10"
	16	6'-11"	7'-2"	7'-5"	7'-7"	7'-9"
	20	8'-8"	9'-0"	9'-3"	9'-6"	9'-9"
	24	10'-5"	10'-9"	11'-1"	11'-4"	11'-8"
	28	12'-2"	12'-7"	12'-11"	13'-3"	13'-8"
PWI-50	8	3'-8"	3'-9"	3'-10"	3'-11"	
	12	5'-6"	5'-7"	5'-9"	5'-11"	
	16	7'-4"	7'-6"	7'-8"	7'-11"	
	20	9'-2"	9'-5"	9'-8"	9'-11"	
	24	11'-0"	11'-3"	11'-7"	11'-11"	
	28	12'-10"	13'-2"	13'-6"	13'-11"	
PWI-60	8	3'-7"	3'-8"	3'-10"	3'-11"	
	12	5'-5"	5'-7"	5'-9"	5'-10"	
	16	7'-3"	7'-5"	7'-8"	7'-10"	
	20	9'-1"	9'-4"	9'-7"	9'-9"	
	24	10'-11"	11'-2"	11'-6"	11'-9"	
	28	12'-8"	13'-1"	13'-5"	13'-8"	
PWI-70	12	5'-3"	5'-5"	5'-7"	5'-9"	5'-11"
	16	7'-1"	7'-3"	7'-5"	7'-8"	7'-10"
	20	8'-10"	9'-1"	9'-4"	9'-7"	9'-10"
	24	10'-7"	10'-11"	11'-2"	11'-6"	11'-10"
	28	12'-5"	12'-9"	13'-1"	13'-5"	13'-9"
	32	14'-2"	14'-7"	14'-11"	15'-4"	15'-9"
PWI-77 (depths to 20")	12	5'-7"	5'-8"	5'-10"	5'-11"	
	16	7'-5"	7'-7"	7'-10"	7'-11"	
	20	9'-4"	9'-6"	9'-9"	9'-11"	
	24	11'-2"	11'-5"	11'-9"	11'-11"	
	28	13'-0"	13'-4"	13'-8"	13'-11"	
	32	14'-11"	15'-3"	15'-8"	15'-11"	
PWI-90 (depths to 20")	12	5'-7"	5'-8"	5'-10"	5'-11"	
	16	7'-5"	7'-7"	7'-9"	7'-11"	
	20	9'-4"	9'-6"	9'-8"	9'-11"	
	24	11'-2"	11'-5"	11'-8"	11'-10"	
	28	13'-1"	13'-4"	13'-7"	13'-10"	
32	14'-11"	15'-3"	15'-7"	15'-10"		

For depths greater than 20", use beam sizing software to size and locate duct holes.

GENERAL NOTES:

1. Table values apply to joists sized by means of the load or span tables in this publication. Use beam sizing software for a more precise analysis or to analyze conditions outside of the scope of these tables.
2. Web holes may be located anywhere between the joist flanges. Leave at least 1/8 inch clearance between the edges of holes and the flanges.
3. Do not cut rectangular holes, or round holes larger than 1 1/2 inch diameter, in cantilevers.
4. The horizontal clearance between the edges of adjacent holes must be at least twice the diameter (or longest side) of the larger hole. Exception: A 1 1/2 inch diameter hole may be drilled anywhere in the web. Provide at least 3 inches of horizontal clearance from adjacent holes of any size.
5. 1 1/2 inch diameter holes are factory-scored in the web at 16 inches on center.

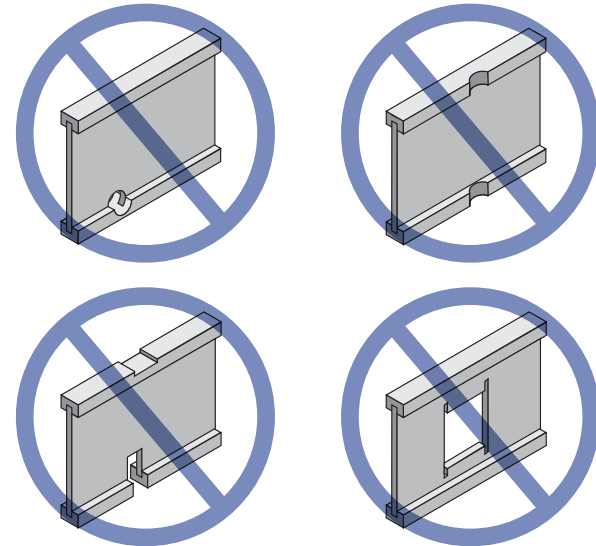

Never drill, cut or notch the flange, or over-cut the web.

Holes in webs should be cut with a sharp saw.

For rectangular holes, avoid over cutting the corners, as this can cause unnecessary stress concentrations. Slightly rounding the corners is recommended. Starting the rectangular hole by drilling a 1" diameter hole in each of the 4 corners and then making the cuts between the holes is another good method to minimize damage to I-joists.

WEB HOLE SPECIFICATIONS

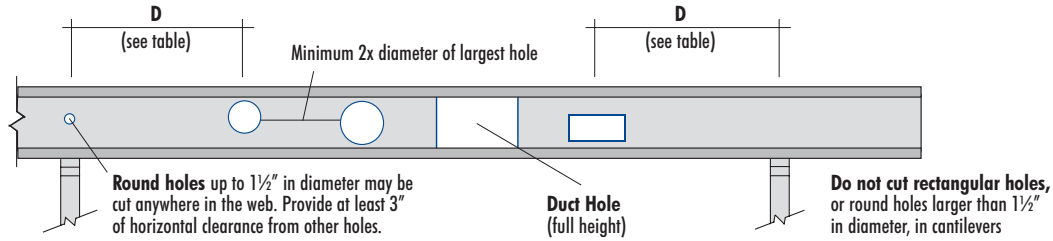

GENERAL NOTES:

1. Table values apply to joists sized by means of the load or span tables in this publication. Use beam sizing software for a more precise analysis or to analyze conditions outside of the scope of these tables.
2. Web holes may be located anywhere between the joist flanges. Leave at least 1/8 inch clearance between the edges of holes and the flanges.
3. Do not cut rectangular holes, or round holes larger than 1 1/2 inch diameter, in cantilevers.
4. The horizontal clearance between the edges of adjacent holes must be at least twice the diameter (or longest side) of the larger hole. Exception: A 1 1/2 inch diameter hole may be drilled anywhere in the web. Provide at least 3 inches of horizontal clearance from adjacent holes of any size.
5. 1 1/2 inch diameter holes are factory-scored in the web at 16 inches on center.

ROUND AND RECTANGULAR HOLES

		Minimum Distance 'D' From Any Support to the Centerline of the Hole													
Round Hole Diameter		2"	3"	4"	5"	6"	6 1/4"	8 5/8"	10"	10 3/4"	12"	12 1/4"	14 1/4"	16 3/4"	
Rectangular Hole Side		1 1/2"	2 1/4"	3"	3 3/4"	4 1/2"	4 5/8"	6 3/8"	7 1/2"	8"	9"	9 1/2"	11"	12 1/2"	
9 1/4" Joist	Span (ft)	8	1'-1"	1'-8"	2'-2"	2'-9"	3'-3"								
		12	1'-8"	2'-6"	3'-3"	4'-1"	4'-11"								
		16	2'-2"	3'-3"	4'-4"	5'-5"	6'-6"								
9 1/2" Joist	Span (ft)	8	1'-1"	1'-7"	2'-1"	2'-8"	3'-2"	3'-3"							
		12	1'-7"	2'-4"	3'-2"	3'-11"	4'-9"	4'-11"							
		16	2'-1"	3'-2"	4'-3"	5'-3"	6'-4"	6'-7"							
11 1/8" Joist	Span (ft)	8	1'-1"	1'-2"	1'-7"	2'-0"	2'-5"	2'-7"	3'-7"						
		12	1'-1"	1'-9"	2'-5"	3'-0"	3'-8"	3'-10"	5'-5"						
		16	1'-5"	2'-4"	3'-2"	4'-1"	4'-11"	5'-2"	7'-2"						
		20	1'-10"	2'-11"	4'-0"	5'-1"	6'-2"	6'-5"	9'-0"						
14" Joist	Span (ft)	12	1'-1"	1'-2"	1'-5"	2'-0"	2'-8"	2'-10"	4'-3"	5'-1"	5'-6"				
		16	1'-1"	1'-2"	1'-11"	2'-9"	3'-6"	3'-9"	5'-8"	6'-9"	7'-4"				
		20	1'-1"	1'-5"	2'-5"	3'-5"	4'-5"	4'-8"	7'-1"	8'-5"	9'-3"				
		24	1'-1"	1'-8"	2'-10"	4'-1"	5'-4"	5'-7"	8'-6"	10'-2"	11'-1"				
16" Joist	Span (ft)	12	1'-1"	1'-2"	1'-2"	1'-3"	1'-5"	1'-6"	3'-0"	3'-10"	4'-3"	5'-1"	5'-6"		
		16	1'-1"	1'-2"	1'-2"	1'-3"	1'-10"	2'-1"	4'-0"	5'-1"	6'-9"	7'-4"			
		20	1'-1"	1'-2"	1'-2"	1'-3"	2'-4"	2'-7"	5'-0"	6'-5"	7'-2"	8'-5"	9'-2"		
		24	1'-1"	1'-2"	1'-2"	1'-7"	2'-9"	3'-1"	6'-0"	7'-8"	8'-7"	10'-1"	11'-0"		
		28	1'-1"	1'-2"	1'-2"	1'-10"	3'-3"	3'-7"	7'-0"	8'-11"	10'-0"	11'-10"	12'-10"		
18" Joist	Span (ft)	12	1'-1"	1'-2"	1'-2"	1'-3"	1'-3"	1'-3"	1'-7"	2'-6"	2'-11"	3'-9"	4'-2"	5'-5"	
		16	1'-1"	1'-2"	1'-2"	1'-3"	1'-3"	1'-3"	2'-2"	3'-3"	3'-11"	5'-0"	5'-7"	7'-3"	
		20	1'-1"	1'-2"	1'-2"	1'-3"	1'-3"	1'-3"	2'-8"	4'-1"	4'-11"	6'-2"	7'-0"	9'-1"	
		24	1'-1"	1'-2"	1'-2"	1'-3"	1'-3"	1'-3"	3'-2"	4'-11"	5'-10"	7'-5"	8'-5"	10'-11"	
		28	1'-1"	1'-2"	1'-2"	1'-3"	1'-3"	1'-3"	3'-9"	5'-9"	6'-10"	8'-8"	9'-9"	12'-9"	
20" Joist	Span (ft)	16	1'-1"	1'-2"	1'-2"	1'-3"	1'-3"	1'-3"	1'-4"	1'-10"	2'-5"	3'-6"	4'-1"	5'-9"	7'-4"
		20	1'-1"	1'-2"	1'-2"	1'-3"	1'-3"	1'-3"	1'-4"	2'-3"	3'-1"	4'-4"	5'-1"	7'-2"	9'-2"
		24	1'-1"	1'-2"	1'-2"	1'-3"	1'-3"	1'-3"	1'-4"	2'-9"	3'-8"	5'-2"	6'-1"	8'-7"	11'-0"
		28	1'-1"	1'-2"	1'-2"	1'-3"	1'-3"	1'-3"	1'-4"	3'-2"	4'-3"	6'-1"	7'-2"	10'-0"	12'-10"
		32	1'-1"	1'-2"	1'-2"	1'-3"	1'-3"	1'-3"	1'-5"	3'-8"	4'-11"	6'-11"	8'-2"	11'-5"	14'-8"
22" Joist	Span (ft)	16	1'-1"	1'-2"	1'-2"	1'-3"	1'-3"	1'-3"	2'-7"	3'-4"	3'-9"	4'-5"	4'-10"	6'-0"	7'-1"
		20	1'-1"	1'-2"	1'-2"	1'-3"	1'-5"	1'-7"	3'-2"	4'-2"	4'-8"	5'-7"	6'-1"	8'-10"	
		24	1'-1"	1'-2"	1'-2"	1'-3"	1'-8"	1'-10"	3'-10"	5'-0"	5'-7"	6'-8"	7'-3"	8'-11"	10'-7"
		28	1'-1"	1'-2"	1'-2"	1'-3"	1'-11"	2'-2"	4'-6"	5'-10"	6'-7"	7'-9"	8'-6"	10'-5"	12'-5"
		32	1'-1"	1'-2"	1'-2"	1'-3"	2'-3"	2'-6"	5'-2"	6'-8"	7'-6"	8'-11"	9'-9"	11'-11"	14'-2"
24" Joist	Span (ft)	16	1'-1"	1'-2"	1'-2"	1'-3"	1'-3"	1'-3"	1'-10"	2'-7"	3'-0"	3'-8"	4'-2"	5'-1"	6'-2"
		20	1'-1"	1'-2"	1'-2"	1'-3"	1'-3"	1'-3"	2'-3"	3'-2"	3'-8"	4'-6"	5'-0"	6'-4"	7'-8"
		24	1'-1"	1'-2"	1'-2"	1'-3"	1'-3"	1'-3"	2'-9"	3'-10"	4'-5"	5'-5"	6'-0"	7'-8"	9'-3"
		28	1'-1"	1'-2"	1'-2"	1'-3"	1'-3"	1'-3"	3'-2"	4'-6"	5'-2"	6'-4"	7'-0"	8'-11"	10'-9"
32	1'-1"	1'-2"	1'-2"	1'-3"	1'-3"	1'-3"	3'-8"	5'-2"	5'-11"	7'-3"	8'-1"	10'-2"	12'-4"		

ROOF INSTALLATION DETAILS

ROOF NOTES:

1. Use minimum 2½" x 0.131" nails unless otherwise noted. Larger diameter nails might split flanges.
2. Fasten joists to top plate with at least two nails. Start nails at least 1½" from end to avoid splitting.
3. Engineered projects might require higher strength connections. Refer to designer's specifications.
4. 1¼" min. bearing at end supports. 3½" at intermediate and cantilever supports.
5. Framing lumber is assumed to be S-P-F unless otherwise noted.
6. See *Web Stiffener Requirements* in this guide.
7. Joists sloped more than ¼ in 12 must be birdsmouth-cut or set on sloped supports (e.g. beveled wall plates, sloped-seat hangers).
8. Birds-mouth cuts are allowed only at low end supports. Do not make birdsmouth cuts at high end supports or at intermediate supports.
9. Details apply to joists sloped up to 12 in 12.
10. Lateral support, to prevent lateral movement and rotation, is required at all supports.
11. Attach straps and hangers according to manufacturer's instructions.

R1 LATERAL SUPPORT

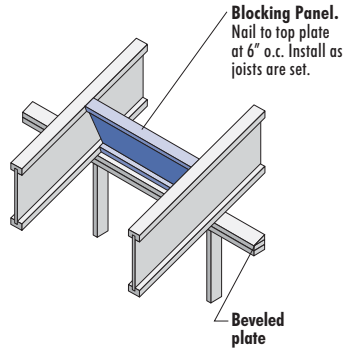

R2 LATERAL SUPPORT

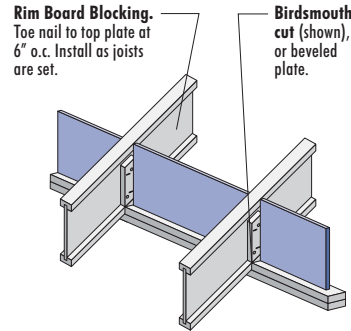

R3 VENTILATION HOLES

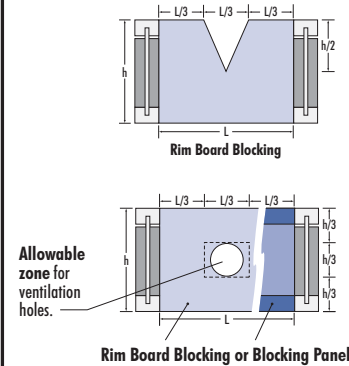

R4 BIRDSMOUTH CUT

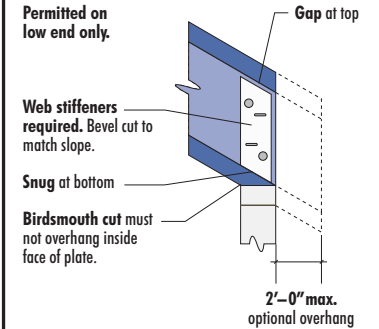

R5 OVERHANG

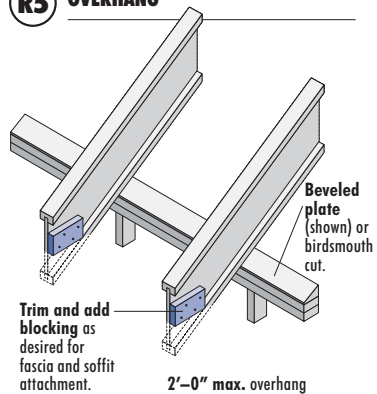

R6 OVERHANG

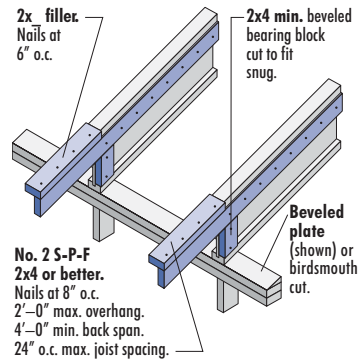

R7 OVERHANG

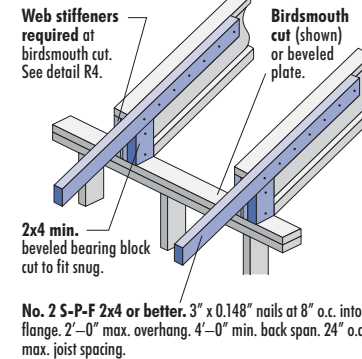

R8 PEAK

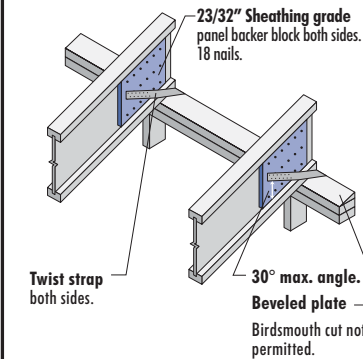

R9 PEAK

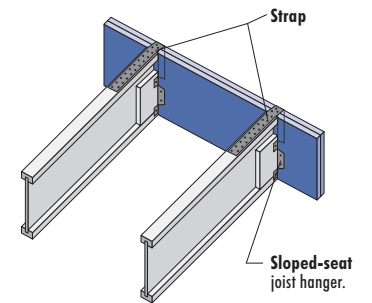

R10 RIDGE

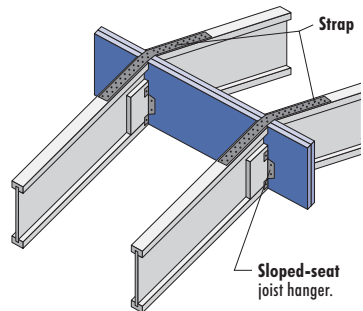

R11 RIDGE

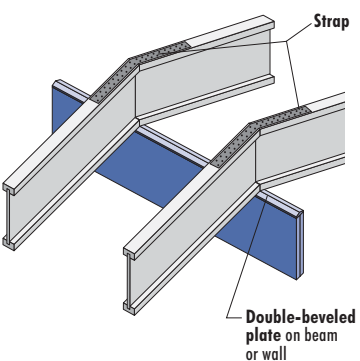

R12 RIDGE

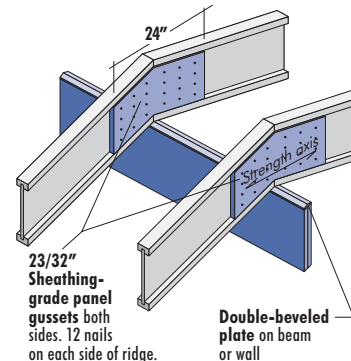

R13 ROOF OPENING

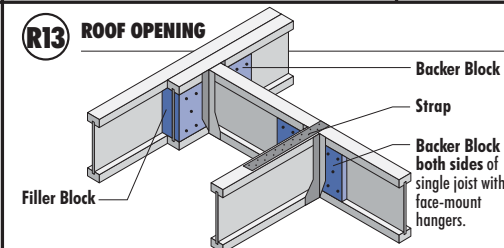

Side Load	Backer Nails	Filler Nails	Joist Flange Width	Filler Block Nail Length	Filler Thickness	Backer Thickness
500 lb	8	4	1½"	2½" min.	1½" or 1¼"	½" or ⅝"
750 lb	12	6	1¾"	3" min.	1¾"	¾"
1000 lb	16	8	2" min.	3" min.	1¾"	¾"
1250 lb	20	10	2½"	3" min.	1¾"	¾"
1500 lb	24	12	2½"	3¼" min.	2"	1"
1750 lb	28	14	2½"	3¼" min.	2" or 2¼"	1" or 1½"
2000 lb	32	16	3½"	3" min. ea. side	3"	1½"

Notes:

1. Side Load is the concentrated load transferred by a joist hanger.
2. Use min. 0.131" diameter nails. For backer blocks, use 2½" nails. For filler blocks, use length shown in table. Note that some joists require filler block nailing from each side.
3. Use Sheathing grade panels, Utility grade S-P-F Lumber, or better. Thinner blocks may be combined to achieve specified thicknesses.
4. Size and position blocks to receive all nails, including hanger nails, without splitting.
5. Max. block depth is joist depth minus 3/8" to avoid an interference fit between flanges.
6. For top-mount hangers, install backer blocks snug to top flange.
7. Clinch nails when possible.
8. Attach hangers according to manufacturer's instructions.

LVL HOLE DETAILS

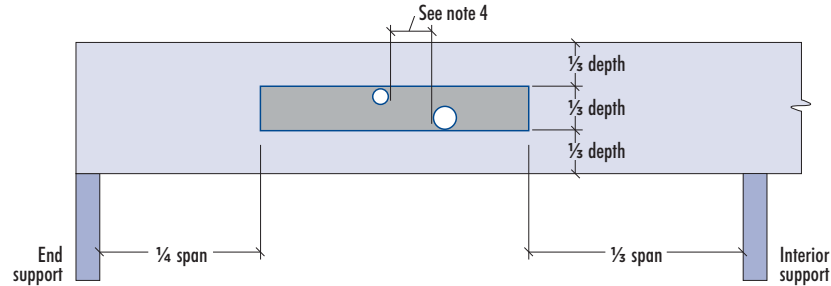

Notes:

1. This technical note applies only to uniformly loaded, simple and multiple span LVL beams. Beams that carry concentrated loads, or cantilevered beams, are outside the scope of this technical note.
2. Square and rectangular holes are not permitted.
3. Round holes may be drilled or cut with a hole saw anywhere within the shaded area of the LVL beam.
4. The horizontal distance between adjacent holes must be at least two times the size of the larger hole. This restriction also applies to the location of access holes relative to bolt holes in multi-ply LVL beams.
5. Do not drill more than three access holes in any four foot long section of LVL beam.

6. The maximum round hole diameter permitted is:

LVL Beam Depth	5 1/2"	7 1/4"	9 1/2" to 24"
Maximum Hole Diameter	3/4"	1"	2"

7. These limitations apply to holes drilled for plumbing or wiring access only. The size and location of holes drilled for fasteners are governed by the provisions of the *National Design Specification® for Wood Construction*.
8. LVL beams deflect under load. Size holes to provide clearance where required.

MULTIPLE-PLY LVL BEAM ASSEMBLY

COMBINATIONS OF 1 3/4" AND 3 1/2" PLYS

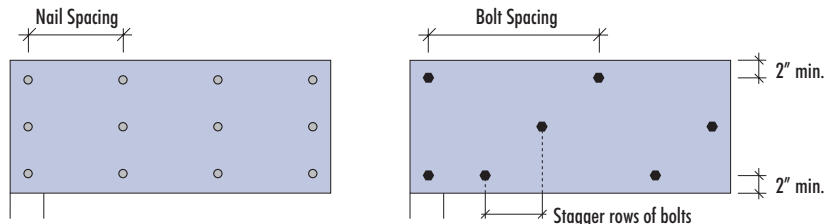
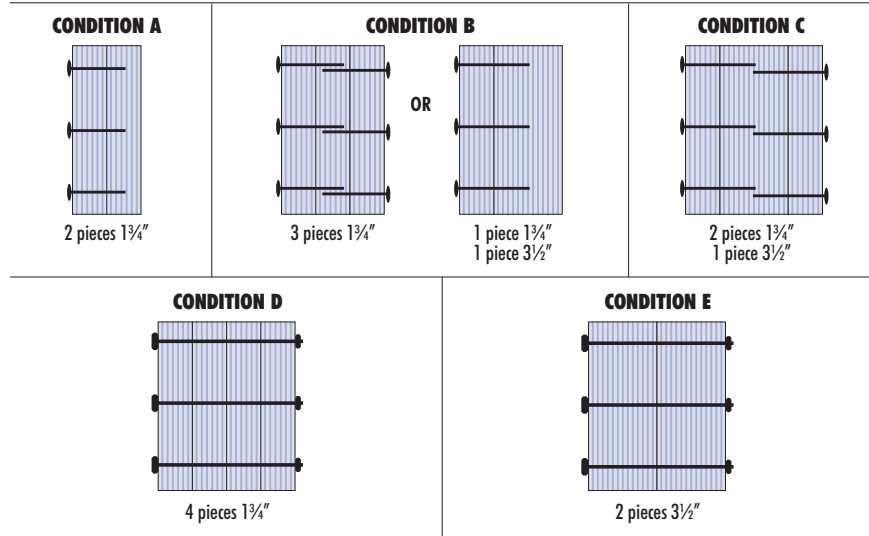

1 3/4" AND 3 1/2" PLYS—MAXIMUM UNIFORM SIDE LOAD (PLF)

Condition	3 1/2" x 0.131" Nails		16d Common Nails		1/2" Bolts		
	2 Rows at 12" o.c.	3 Rows at 12" o.c.	2 Rows at 12" o.c.	3 Rows at 12" o.c.	2 Rows at 24" o.c.	2 Rows at 12" o.c.	3 Rows at 12" o.c.
Condition A (2-1 3/4")	390	585	565	845	510	1015	1520
Condition B (3-1 3/4" OR 1-1 3/4" + 1-3 1/2")	290	435	425	635	380	765	1145
Condition C (2-1 3/4" + 1-3 1/2")	260	390	375	565	465	930	1395
Condition D (4-1 3/4")	use bolts for this condition				340	680	1015
Condition E (2-3 1/2")	use bolts for this condition				860	1720	2580

Notes:

1. Minimum fastener schedule for smaller side loads and top-loaded beams:
 Conditions A, B & C, beams 12" deep or less:
 2 rows 3 1/2" x 0.131" at 12" o.c.
 Conditions A, B & C, beams deeper than 12":
 3 rows 3 1/2" x 0.131" at 12" o.c.
 Conditions D & E, all beam depths:
 2 rows 1/2" bolts at 24" o.c.
2. The table values for nails may be doubled for 6" o.c. and tripled for 4" o.c. nail spacings.
3. The nail schedules shown apply to both sides of a three-ply beam.
4. The table values apply to common bolts that conform to ANSI/ASME Standard B18.2.1-1981. A washer not less than a standard cut washer shall be between the wood and the bolt head and between the wood and the nut. The distance from the edge of the beam to the bolt holes must be at least 2" for 1/2" bolts. Bolt holes shall be the same diameter as the bolt.
5. 7" wide beams must be loaded from both sides and/or top loaded.
6. Beams wider than 7" must be designed by the engineer of record.
7. Load duration factors may be applied to the table values.

HOW TO USE THE MAXIMUM UNIFORM SIDE LOAD TABLE

EXAMPLE:

THREE 1 3/4" PLYS LOADED FROM BOTH SIDES AND ABOVE (CONDITION B)

1. Use allowable load tables or sizing software to size the beam to carry a total load of $(300 + 610 + 550) = 1460$ plf.
2. Refer to the Condition B row in the table. Scan across the row from left to right for a table value greater than 550 plf, which is the greatest side load carried by the beam. The fourth value in the row indicates that 3 rows of 16d common nails at 12" o.c. will accommodate a side load of 635 plf which is greater than the 550 plf required. Use 3 rows of 16d common nails at 12" o.c., from both sides, to assemble the beam.

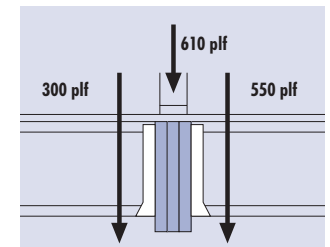

HANDLING & INSTALLATION

- LVL should be stored lying flat and protected from the weather.
- Keep the material above ground to minimize the absorption of ground moisture and allow circulation of air.
- LVL is for use in covered, dry conditions only. Protect from the weather on the job site both before and after installation.
- Except for cutting to length, LVL shall not be cut, drilled or notched. Heel cuts may be possible. Contact your Pacific Woodtech representative.
- Do not install any damaged LVL.

BEARING DETAILS

B1 BEAM-TO-BEAM CONNECTION

Make sure hanger capacity is appropriate for each application. Hangers must be properly installed to accommodate full capacity.

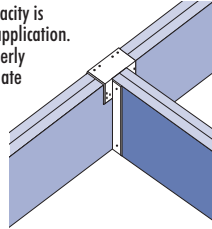

B2 BEARING ON WOOD COLUMN

Verify the required bearing area and the ability of the supporting column member to provide adequate strength.

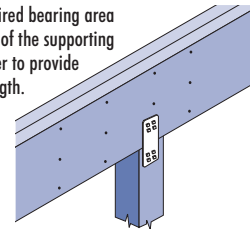

B3 BEARING ON STEEL COLUMN

Verify the required bearing area and the ability of the supporting column member to provide adequate strength.

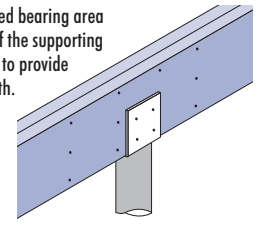

B4 BEARING ON EXTERIOR WALL

Prevent direct contact of LVL with concrete. Consult local building code for requirements.

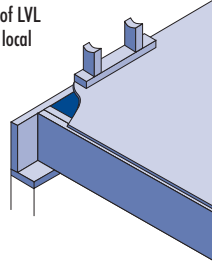

B5 BEARING FOR DOOR OR WINDOW HEADER—1-STORY TYPICAL

See "Bearing Length Requirements" below.

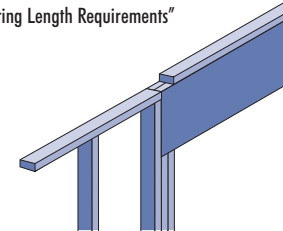

B6 WINDOW/DOOR HEADER—2-STORY TYPICAL

See "Bearing Length Requirements" below.

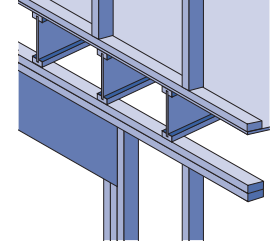

BEARING LENGTH REQUIREMENTS

LVL BEARING LENGTH REQUIREMENTS

Support Material	S-P-F (South) Hem-Fir (North) ⁽⁵⁾		Hem-Fir S-P-F ⁽⁵⁾		Southern Pine Douglas Fir – Larch ⁽⁵⁾		1.5E LVL ⁽⁶⁾		1.8E or 2.0E LVL ⁽⁶⁾	
	F _{cL} (psi)		405		565		575		850	
LVL Beam Width (in)	1 3/4"	3 1/2"	1 3/4"	3 1/2"	1 3/4"	3 1/2"	1 3/4"	3 1/2"	1 3/4"	3 1/2"
Reaction (x 1000 lbs)	1	3"	1 1/2"	1 1/2"	1 1/2"	1 1/2"	1 1/2"	1 1/2"	1 1/2"	1 1/2"
	2	3 1/2"	3"	3"	1 1/2"	3"	1 1/2"	3"	1 1/2"	1 1/2"
	3	5 1/2"	3"	4 1/2"	3"	3 1/2"	3"	4 1/2"	3"	1 1/2"
	4	7 1/4"	3 1/2"	6"	3"	4 1/2"	3"	6"	4 1/2"	3"
	5	9 1/4"	4 1/2"	7 1/4"	4 1/2"	5 1/2"	3"	7 1/2"	5 1/2"	3 1/2"
	6		5 1/2"	9 1/4"	4 1/2"	7 1/4"	3 1/2"	9"	6"	4 1/2"
	7		6"		5 1/2"	7 1/4"	4 1/2"		7 1/2"	5 1/2"
	8		7 1/4"		6"	9 1/4"	4 1/2"		9"	5 1/2"
	9		9 1/4"		7 1/4"	9 1/4"	5 1/2"		9"	7 1/2"
	10		9 1/4"		7 1/4"		5 1/2"		7 1/2"	3 1/2"
	11				9 1/4"		6"		7 1/2"	4 1/2"
	12				9 1/4"		7 1/4"		9"	4 1/2"

LVL BEARING LENGTH REQUIREMENTS

Support Material	S-P-F (South) Hem-Fir (North) ⁽⁵⁾		Hem-Fir S-P-F ⁽⁵⁾		Southern Pine Douglas Fir – Larch ⁽⁵⁾		1.5E LVL ⁽⁶⁾		1.8E or 2.0E LVL ⁽⁶⁾	
	F _{cL} (psi)		405		565		575		850	
LVL Beam Width (in)	1 3/4"	3 1/2"	1 3/4"	3 1/2"	1 3/4"	3 1/2"	1 3/4"	3 1/2"	1 3/4"	3 1/2"
Reaction (x 1000 lbs)	13			9 1/4"		7 1/4"			9"	4 1/2"
	14					7 1/4"				5 1/2"
	15					9 1/4"				5 1/2"
	16					9 1/4"				5 1/2"
	17					9 1/4"				6"
	18					9 1/4"				7 1/2"
	19									7 1/2"
	20									7 1/2"
	21									7 1/2"
	22									7 1/2"
	23									9"

Notes:

- The minimum required bearing length is 1 1/2".
- Duration of load factors may not be applied to bearing length requirements.
- All LVL beams require support across their full width.
- All LVL beams require lateral support at bearing points.
- Use these values when the LVL beam is supported by a wall plate, sill plate, timber or built-up girder.
- Use these values when the LVL beam is supported by the end of a column or connection hardware.
- The support member must be sized to carry the load from the LVL beam.